

Disassembly
& Assembly
Instructions
for **Liquid Ring
Vacuum Pumps
with Mechanical
Seals**

SERIES TRH-TRS-TRM-TRV



200 NEWSOME DRIVE
YORKTOWN, VA 23692
Telephone: 757.988.3930
Toll Free: 800.535.4243
Fax: 757.988.3975

Web Site: www.travaini.com

Continuing research of TRAVAINI PUMPS USA results in product improvements; therefore any specifications may be subject to change without notice.

PRINTED IN USA
F:/MVUOTGB4

DATE 4/02



TABLE OF CONTENTS

PAGE

Section One: TRH and TRS

Introduction	2
1 Disassembly to replace bearings and/or mechanical seals	3
2 Mechanical seal assembly	5
2.1 Assembly of the stationary part in the bearing housing	5
2.2 Assembly of the rotating part on the shaft	6
3 Bearing assembly	7
3.1 Securing the bearings (not for pumps series 32)	10
4 Bearing lubrication	11
5 Total pump disassembly	12
6 Machining the pump parts	14
6.1 Typical schematics for machining to restore clearances - Pumps series "TRH"	16
6.2 Typical schematics for machining to restore clearances - Pumps series "TRS - TRV"	18
7 Pump assembly	20
7.1 Pumps series "TRHE & TRSE 32"	20
7.2 Pumps series "TRH 40 to 100 - TRS 40 to 125 - TRV 65" ...	22
8 Recommended spare parts	29
9 Parts list	30
10 Typical sectional drawings	31

Section Two: TRMB and TRVB

Introduction	49
11 Pump disassembly	50
11.1 Disassembly of pump series TRMB	50
11.2 Disassembly of pump series TRVB	50
12 Pump assembly	51
12.1 Assembly of pump series TRMB	51
12.2 Assembly of pump series TRVB	53
13 Recommended spare parts	55
14 Parts list	56
15 Typical sectional drawings	57

Section Three:

Warranty Policy	65
------------------------------	----

In preparing this manual, every possible effort has been made to help the customer and operator with the proper installation and operation of the pump. Should you find errors, misunderstandings or discrepancies please do not hesitate to bring them to our attention.

SECTION ONE: TRH AND TRS

INTRODUCTION

These instructions are for the maintenance staff in case of repair for the following pumps:

TRHE 32-20 to 60	TRSE 32	TRVA 65
TRHC 40-110	TRSC 40	
TRHE 40-110	TRSE 40	
TRHC 40-140 & 190	TRSC 50	
TRHE 40-140 & 190	TRSE 50	
TRHC 80	TRSC 100	
TRHE 100	TRSE 125	

These instructions are supplied and integrated with the manual of "INSTALLATION, OPERATION AND MAINTENANCE INSTRUCTIONS FOR LIQUID RING VACUUM PUMPS". They provide a reference for safe operation, installation, maintenance and repairing of the pumps.

Prior to working on the pump it is recommended to follow the instructions of safety listed in chapters 2 and 15 of the above manual, and is absolutely important to:

- wear safety clothing, hard hat, safety shoes, safety eye glasses
- disconnect the electrical power
- close suction valves and service liquid valves
- remove pump from installation without damaging other system components
- assume all safety measures if pump has been handling dangerous fluids
- drain pump casings through the draining connections and flush the pump with clean liquid, if required.

The pump type and part number are stamped on the pump nameplate, it is always required to refer to this number when ordering spare parts or when requesting further technical information.

Assembly and disassembly requires a particular knowledge of the operations to be carried out: therefore, please read these instructions carefully and if the information given is not sufficient and/or easily understandable, it is recommended to send the pump to Travaini Pumps USA or its closest authorised representative.

Any pump repairs and/or system work carried out by others will not be warranted by Travaini Pumps USA.

NOTE: VDMA numbers identify all pump components. Refer to parts list in chapter 9 and to the section drawings in chapter 10.

All drawings are schematic only and are not certified for construction. For further information please consult Travaini Pumps USA or its closest representative.

Torque values of various bolt sizes and tie-bolts are listed on figure 34 and Table 13.

1 - DISASSEMBLY TO REPLACE BEARINGS AND/OR MECHANICAL SEALS

The pumps are manufactured in such a manner as to make it possible to replace the mechanical seals and the bearings without total disassembly of the pump, but only by removing the bearing housings VDMA 357 or VDMA 350.

Bearing housing disassembly can be carried out by following the sequence listed on table 1 and 2. Following the row of the specific pump model, find the sequence and the numeric quantity of the components to be disassembled.

In order to remove the bearing housings a suitable gear puller is required.

NOTE: Pumps series 32 have free floating impellers. To prevent the shaft from sliding out of the pump, it is recommended to remove and replace the mechanical seal, bearing housing and bearings one side at a time, or make provision to secure the shaft so it does not slide out of the pump.

WARNING: Handle the mechanical seals with care to prevent damaging their most delicate parts.

Table 1 - DISASSEMBLY OF BEARING AND MECHANICAL SEAL - DRIVE END

COMPONENT VDMA NO.	PIPE	CIRCLIP	SCREW	SCREW	BEARING COVER	CIRCLIP	NUT	SCREW	SCREW	BEARING HOUSING	BEARING	ELASTIC RING	SHOULDER RING	GASKET	MECHANICAL SEAL	MECHANICAL SEAL BUSH					
PUMP SERIES	701	932.3	914	901	365	360	932	923	914.1	901.1	357	357.1	320	323	935	505	505.1	400.2	433.2	485	
TRHE 32-20 to 60 TRSE 32		1			1	1	4			1	1				1	1					
TRHC 40-110 TRSC 40		1			1	1	4			1	1				1	1					
TRHE 40-110 TRSE 40		1			1	1	4			1	1				1	1					
TRHC 40-140 & 190 TRSC 50			4		1	1	4			1	1				1	1					
TRHE 40-140 & 190 TRSE 50			4		1	1	4			1	1				1	1					
TRHB 50	1		4		1	1	4			1	1				1	1					
TRSB 100			4		1	1	4	1		1					1	1	1	1			
TRHC 80 TRSC 100			4		1	1	4	1		1					1	1					
TRHE 100 TRSE 125			4		1	1	4	1		1	1	1	1	1	1	1					
TRVA 65			4		1	1	4			1	1				1	1					

Table 2 - DISASSEMBLY OF BEARING AND MECHANICAL SEAL - NON DRIVE END

COMPONENT VDMA NO.	PIPE	CIRCLIP	SCREW	SCREW	BEARING COVER	ELASTIC RING	NUT	CIRCLIP	SCREW	SCREW	BEARING HOUSING	BEARING	ELASTIC RING	SHOULDER RING	GASKET	MECHANICAL SEAL	MECHANICAL SEAL RING					
PUMP SERIES	701	932.3	914	901	365.1	360.1	935	923	932	914.1	901	901.1	357	357.1	320	935	505	400.2	433.1	485	485.1	
TRHE 32-20 to 60 TRSE 32		1			1				1	4		1	1	1	1	1						
TRHC 40-110 TRSC 40			4		1		1			4		1	1		1	1	1	1				
TRHE 40-110 TRSE 40		1			1		1		4			1	1		1	1	1	1				
TRHC 40-140 & 190 TRSC 50			4		1		1			4		1		1	1	1	1	1				
TRHE 40-140 & 190 TRSE 50			4		1		1		4			1	1		1	1	1	1				
TRHB 50	1		4		1		1			4		1	1		2	1	1	1				
TRSB 100			4		1		1			4		1	1		2	1	1	1				
TRHC 80 TRSC 100			4		1		1			4	1		1		2	1	1	1				
TRHE 100 TRSE 125			4		1		1			4	1		1		2	1	1	1				
TRVA 65			4		1		1		4			1	1		2	1	1	1				1

Inspect the disassembled components and procure all original spare parts such as bearings, mechanical seals, gaskets, seal rings, etc. Any non-original spare parts, shall be dimensionally compatible with the sizes and performances of the original component. Carefully clean all parts that are still in good conditions. See chapters 2 and 3 for disassembly instructions of mechanical seals and bearings.

2 - MECHANICAL SEAL ASSEMBLY

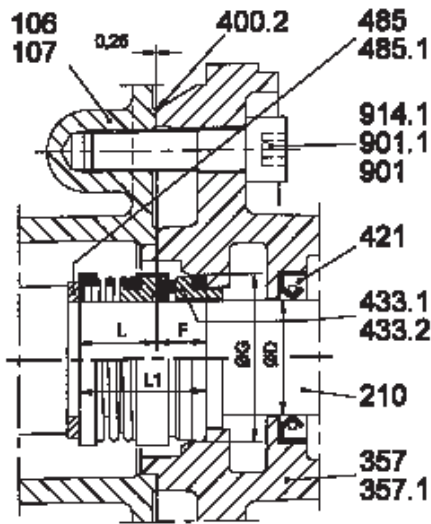

Figure 1 - Typical drawing of mechanical seal with dimensions valid for both pump ends shaft VDMA 210 (whenever possible).

NOTE: The mechanical seals mounted on the pumps are of standard type according to DIN 24960/K (shorter working length "L1").

Prior to assembly, check the dimensions of the cavities for the mechanical seal VDMA 433.1 and/or 433.2. Critical dimensions are "ØG" and "F" on the bearing housing VDMA 357 and/or 357.1 (or on the bushing VDMA 542, when provided), dimension "ØD" of the shaft VDMA 210, dimension "L" from the casings VDMA 106/107 to the ring VDMA 485 (when provided) or the shoulder on shaft VDMA 210 (see drawing figure 1 and dimensions listed on table 3).

Restore, if necessary, the required working dimension "L1" of the mechanical seals by adjusting the location of ring VDMA 485 (when provided) or adding spacer or machining the shoulder of the

Table 3 - DIMENSIONS FOR THE MECHANICAL SEALS

PUMPS SERIES	Ø D h6	F	Ø G H8	L	L1 ±0.5
TRHE 32-20 to 60 TRSE 32	22	2	37	35.5	37.5
TRHE 40-110 TRSE 40	28	18	43	24.5	42.5
TRHC 40 TRHE 40-140 & 190 TRSC 40	35	25	50	17.5	
TRSC 50 TRSE 50					
TRHB 50 TRVA 65	43	16	61	29	45
TRHC 80 TRSB 100 TRSC 100	55	3.5	75	44	47.5
TRHE 100 TRSE 125	75	2	97	58	60

2.1 - ASSEMBLY OF THE STATIONARY PART IN THE BEARING HOUSING

The seat in the bearing housing VDMA 357 or 357.1 where the seal ring fits, shall be perfectly clean and without machining tool markings.

Moisten (using water, liquid soap, etc., but avoiding the use of oils) the seat in the housing and the O-Ring of the stationary part of the mechanical seal.

Push the stationary part of the mechanical seal into the housing using a plunger covered with heavy paper board or similar material. The plunger must exert a force perpendicularly to the axis of the piece; for this purpose use either a harbour press or the spindle of a drill (see figure 2).

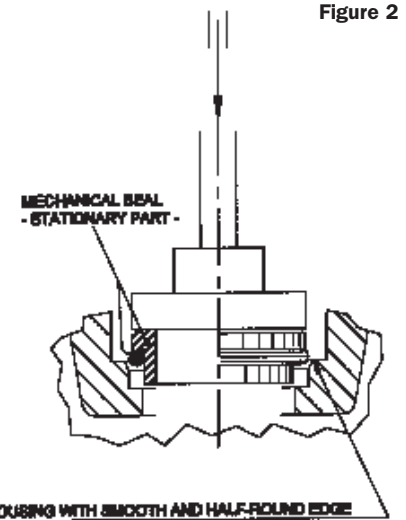

Figure 2

2.2 - ASSEMBLY OF THE ROTATING PART ON THE SHAFT

The area of the shaft VDMA 210 where the seal fits shall be smooth, clean, without sharp edges and moistened (using water, liquid soap, etc: but avoiding the use of oils). Even if the shaft has been ground, it shall be polished again with extra fine sand paper or emery cloth.

Insert the ring VDMA 485 on the shaft (when provided), slip on the whole rotating part of the mechanical seal on the conic sleeve "A", or any similar tool (see figure 3). The surface of the sleeve should be smooth and moistened (using water or liquid soap etc. but avoiding the use of oils).

Gently push the rotating part of the seal, with the help of a tool similar to the device "B", until it rests against the VDMA 485 or the shaft shoulder.

NOTE: Mechanical seals that are designed for specific direction of rotation must be fitted on the pump shaft end having that particular direction of rotation.

Example: Pump with clockwise rotation (viewed from drive-end) requires mechanical seal designed for right rotation at the drive-end side and seal for left rotation at non-drive-end side.

Figure 3

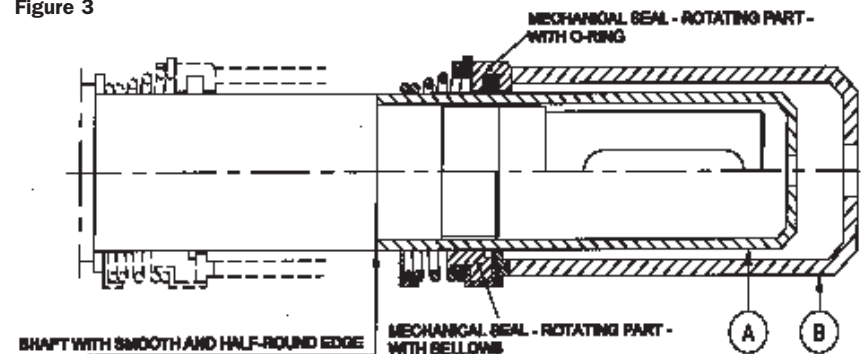
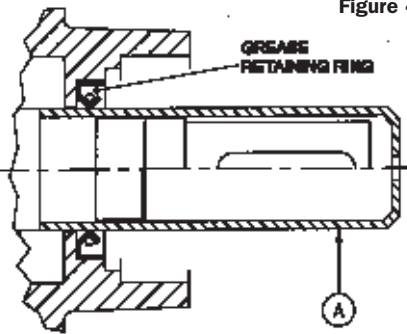

Figure 4

Fit mechanical seal stationary seat and gasket VDMA 400.3 on seal cover VDMA 471. Fit seal cover on pump housing VDMA 106 or 107 and fasten it with bolts VDMA 914. Install bearing housing VDMA 357 complete with radial seal ring VDMA 421 (see fig 4.).

NOTE: Bearing housing draining connection should be positioned toward the bottom.

Provided that the tie-bolts VDMA 905 (and the pump components between them) have never been moved, the bolts VDMA 901.1 can now be tightened to pump housing VDMA 106 and/or 107. Assemble the seal flushing line VDMA 701, where applicable.



3 - BEARING ASSEMBLY

Bearing assembly can only start after the pump has been fitted with mechanical seals and seal housing VDMA 357 or bearing housing VDMA 350, as described in chapter 2.

NOTE: Pumps series 32 have free floating impellers. To prevent the shaft from sliding out of the pump, it is recommended to replace the bearing at non drive end first, or make provision to secure the shaft so it does not slide out of the pump. Proceed with the assembly following the steps given on table 4 and 5 which indicate, on the row of the pump concerned, the sequence and the numeric quantity of the components to be assembled (for additional information see instructions on the following pages).

NOTE: All pumps in the “STANDARD” design, except series TRHE 100 and TRSE 125, are fitted with locked bearings at the non-drive end. Therefore the non-drive end bearing will locate the rotor within the pump while the bearing at the drive end is free to slide in its housing.

See figures 5 to 8 for locking the bearing and table 6 for bearing details.

Table 4 - BEARING ASSEMBLY - DRIVE END

COMPONENT VDMA NO.	SHOULDER RING		BEARING		ELASTIC RING	CIRCLIP	NUT	BEARING COVER		CIRCLIP	SCREW	SCREW
	505	505.1	320	323				365	360			
PUMP SERIES	505	505.1	320	323	935	932	923	365	360	932.3	914	901
TRHE 32-20 to 60												
TRSE 32	1		1			1		1		1		
TRHC 40-110	1		1			1		1		1		
TRSC 40												
TRHE 40-110	1		1			1		1		1		
TRSE 40												
TRHC 40-140 & 190	1		1			1		1		1		
TRSC 50												
TRHE 40-140 & 190	1		1			1		1		1		
TRSE 50												
TRHB 50	1		1				1		1		4	
TRSB 100	1		1				1		1		4	
TRHC 80	1		1				1		1		4	
TRSC 100												
TRHE 100	1	1		1	1		1		1			4
TRSE 125												
TRVA 65	1		1				1		1		4	

Table 5 - BEARING ASSEMBLY - NON DRIVE END

COMPONENT VDMA NO.	SHOULDER RING	ELASTIC RING	BEARING	NUT	ELASTIC RING	CIRCLIP	BEARING COVER		CIRCLIP	SCREW	SCREW
							365.1	360.1			
PUMP SERIES	505	935	320	923	935	932	365.1	360.1	932.3	914	901
TRHE 32-20 to 60	1	1	1			1	1		1		
TRSE 32											
TRHC 40-110	1	1	1	1				1		4	
TRSC 40											
TRHE 40-110	1	1	1	1	1		1		1		
TRSE 40											
TRHC 40-140 & 190	1	1	1	1				1		4	
TRSC 50											
TRHE 40-140 & 190	1	1	1	1				1		4	
TRSE 50											
TRHB 50	2	1	1	1				1		4	
TRSB 100	2	1	1	1				1		4	
TRHC 80	2	1	1	1				1		4	
TRSC 100											
TRHE 100	2	1	1	1				1			4
TRSE 125											
TRVA 65	2	1	1	1				1		4	

See figures 5 to 8 for locking the bearings on “STANDARD” or “BELT DRIVE” pump designs (series 32 not available with belt drive).

Figure 5
Locking of bearings
(STANDARD only)
For pumps series

TRHE 32-20 to 60
TRSE 32

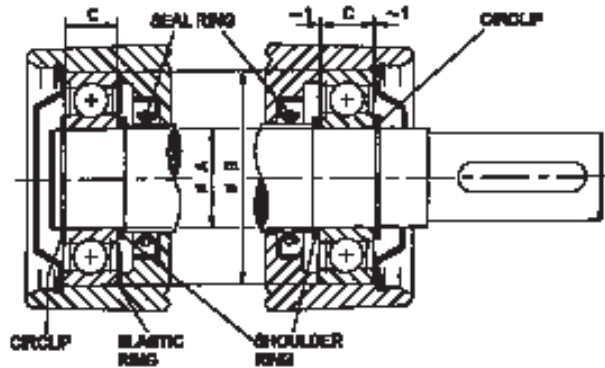

Figure 6
Locking of bearings
for pumps series

TRHE 40-110
TRSE 40

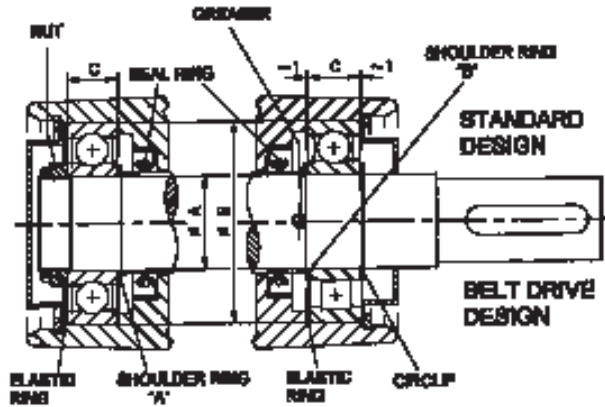

Figure 7
Locking of bearings
for pumps series

TRHC 40 and
TRHE 40-140 & 190
TRSC 40 & 50 and
TRSE 50

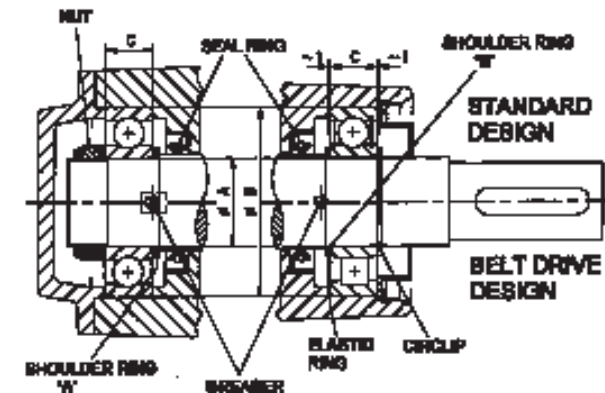

Figure 8
Locking of bearings
for pumps series

TRHB 50 - TRHC 80 -
TRSB 100
TRSC 100 & TRVA 65

TRHE 100
TRSE 125

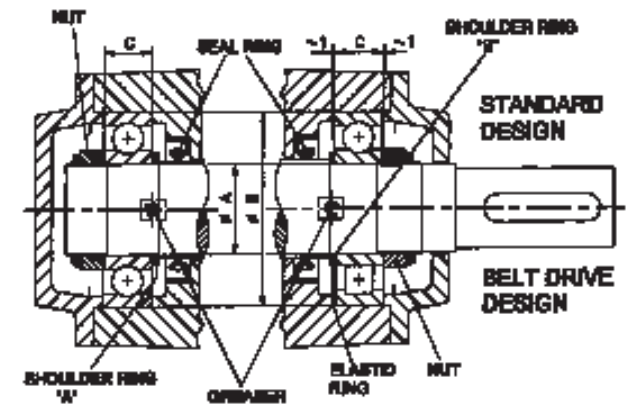

Table 6 - DIMENSIONS AND DETAILS OF BEARINGS

PUMP SERIES	BEARING DIMENSIONS					QUANTITY OF GREASE FOR BEARING in g
	ØA	ØB	C	BALL BEARING TYPE	ROLLER BEARING TYPE	
TRHE 32-20 to 60 TRSE 32	20	52	15	6304-2RS	—	—
TRHE 40-110 TRSE 40 TRHC 40	25	62	17	6305-2RS	NU 305	15
TRHE 40 140 & 190 TRSC 40 TRSC 50 TRSE 50	30	72	19	6306-2RS	NU 306	18
TRHB 50 TRVA 65	40	90	23	6308	NU 308	20
TRHC 80 TRSB 100 TRSC 100	50	110	27	6310	NU 310	35
TRHE 100 TRSE 125	70	150	35	6314	NU 314	50

3.1 - SECURING THE BEARINGS (NOT FOR PUMPS SERIES 32)

Bearing shall be locked in such a way that the impellers VDMA 230 and 230.1 are centred within their own housing.

To find the “A” dimension (thickness) for the shoulder rings VDMA 505 on the non drive end, the pump must have been assembled up to the bearing housings VDMA 357 and/or 357.1 excluding the bearings VDMA 320 and/or 323 and the bearing shoulder rings (see figure 9 and 10).

- Using a gear puller or other suitable tool, push the shaft VDMA 210 in the “X” direction and measure the “X1” dimension (from the shaft shoulder to the face of the bearing housing).
- Repeat the operation pushing the shaft in the “Y” direction and measure the “Y1” dimension (always from the shaft shoulder to the face of bearing housing).

- Measure the “P” dimension (depth of the bearing box).
- Apply the equation $A = [(X1 + Y1) / 2] - P$ which will determine the thickness of spacer VDMA 505.

Finding the “B” dimension that is the thickness of the shoulder ring for the drive end, will depend upon the type of bearing design.

For the “STANDARD” pump design, “B” dimension shall be such as to leave a clearance of about 1 mm on each side of the bearing on the drive side (see figure 9).

Instead, for the “BELT DRIVE” design, “B” dimension shall be such as to place the bearing against the face of the bearing cover VDMA 365.1 or 360.1 and to leave all the clearance (about 2 mm) on the side of the bearing housing, that is required for the assembly of the elastic ring VDMA 935 (see figure 10).

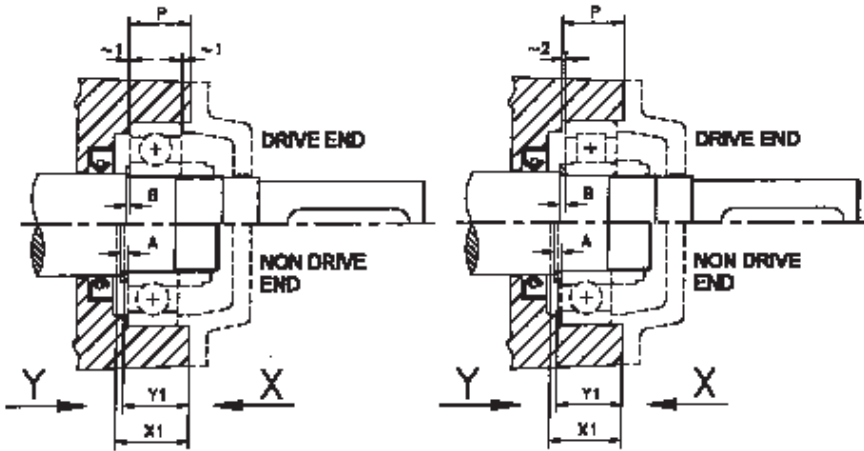

Figure 9
“STANDARD” design

Figure 10
“BELT DRIVE” design

4 - BEARING LUBRICATION

Lubrication of greased open bearings must be done in compliance with the instructions of the bearing manufacturer.

Pumps with standard operating conditions, should have their bearings lubricated after maximum 1000 working hours.

In any case, always check the bearing’s operation for unusual high temperature and noise level.

When considering reusing the bearings, it is recommended to remove the old grease and any dirt from the bearing running faces and seal rings, then fill with new lubricating grease.

The lubricant type used by us is “BEACON EP2” of “ESSO”, namely lithium soap grease with temperature range from -20 °C to +110 °C. It is recommended not to mix different types of grease.

Equivalent grease or grease with greater performances can be used.

Before starting the pump, it is good practise to grease the bearings with a suitable grease gun.

The maximum quantity of required lubricant is listed on table 6.

Lubrication intervals may be increased depending upon the operating temperatures and the bearing loads.

5 - TOTAL PUMP DISASSEMBLY

NOTE: It is suggested to mark the location (rotation and assembly sequence) for the various parts prior to starting the disassembly. However, most parts have a locating marking at 12 O’clock position that can be used as a reference for their position.

A wrong location of the parts can cause a partial or even a total lack of pump performance.

Drain the pump of any residual liquid, prior to disassembly. With the pump in the horizontal position begin the disassembly at the bearing housings and the mechanical seals (see chapter 1).

Then place the pump in the vertical position on a sturdy stand similar to the one illustrated on figure 28 to 31 (section of heavy duty pipe or similar stand) and proceed to disassemble the whole pump (pumps series 32 can also be disassembled in the horizontal position).

Use proper tools and follow a correct disassembly method to avoid damaging the pump components.

See table 7 or 8 (by pumps series), for the sequence and the numeric quantity of parts to disassemble; to help with the identification and the location of all components consult also the sectional drawings on chapter 10.

After pump disassembly inspect all parts for their integrity. If they are in sound condition, clean the parts and remove the gasket material from the sealing faces with a nitro-cellulose thinner.

If the parts require machining, follow the instructions given on chapter 6.

When original spare parts are used, check that they are compatible with the new dimensions obtained by machining the parts.

For the recommended spare parts see chapter 8.

Table 7 - TOTAL PUMP DISASSEMBLY - PUMPS SERIES “TRH”

COMPONENT VDMA NO.	STEP I			STEP II						(STEPS CONTINUED BELOW)	
	BOLT	MANIFOLD	GASKET	TIE-BOLT	SUCTION CASING	PIN	PORT PLATE	GASKET	IMPELLER CASING		GASKET
PUMP SERIES	901.8	147	400.8	905	106	561	137.1	400	110	400	
TRHE 32-20 & 45				3	1			1			
TRHE 32-60	4	1	2	3	1			1			
TRHC 40-110				4	1	1	1	1	1	1	
TRHE 40-110				4	1			1	1	1	
TRHC 40-140 & 190	8	1	2	4	1	1	1	1	1	1	
TRHE 40-140 & 190	8	1	2	4	1			1	1	1	
TRHB 50	8	1	2	5	1			1	1	1	
TRHC 80	8	1	2	5	1	1	1	1	1	1	
TRHE 100	16	1	2	7	1			1	2	2	

Table 8 - TOTAL PUMP DISASSEMBLY - PUMPS SERIES “TRS - TRV”

COMPONENT VDMA NO.	STEP I			STEP II						STEP III			STEP IV					
	BOLT	MANIFOLD	GASKET	TIE-BOLT	SUCTION CASING	PIN	PORT PLATE	GASKET	IMPELLER CASING	GASKET	DISCHARGE CASING	PIN	PORT PLATE	NUT	SPACER SLEEVE	IMPELLER		
PUMP SERIES	901.8	147	400.8	905	106	561	137.1	400	110	110.1	400	107	561	137.4	922	922.1	525	230
TRSE 32				3	1			1	1		1	1						1
TRSC 40-55-100				4	1	1	1	1	1		1	1	1	1		1	1	1
TRSC 40-150	8	1	2	4	1	1	1	1	1		1	1	1	1		1	1	1
TRSE 40				4	1			1	1		1	1			2			1
TRSC 50	16	2	4	4	1	1	1	1	1		1	1	1	1	1	1	1	1
TRSE 50	16	2	4	4	1			1	1		1	1			2			1
TRSB 100	16	2	4	7	1			1	1	1	2	1			2			1
TRSC 100	16	2	4	5	1	1	1	1	1		1	1	1	1	1			1
TRSE 125	32	2	4	7	1			1	1	1	2	1			2			1
TRVA 65	16	2	4	5	1	1	1		1		1	1	1	2				1

Table 7 CONTINUED - TOTAL PUMP DISASSEMBLY - PUMPS SERIES “TRH”

COMPONENT VDMA NO.	STEP III						STEP IV										
	DISCHARGE CASING	PIN	PORT PLATE	GASKET	IMPELLER CASING	GASKET	NUT	SPACER SLEEVE	2ND STAGE IMPELLER	PORT PLATE	PIN	PORT PLATE	INTERMEDIATE ELEMENT	SPACER SLEEVE	1ST STAGE IMPELLER		
PUMP SERIES	107	561	137.4	400	110.1	400	922	922.1	525	230.1	137.3	561	137.2	140	140.1	521	230
TRHE 32-20 to 60	1			1						1				1			1
TRHC 40-110/ GH - F - RA	1	1	1			1		1	1					1		1	1
TRHC 40-110/ B2 - A3	1	1	1	1	1	1	2		1	1	1	1				1	1
TRHE 40-110	1					1	2		1					1		1	1
TRHC 40-140 & 190/ GH - F - RA	1	1	1			1		1	1					1		1	1
TRHC 40-140 & 190/ B2 - A3	1	1	1	1	1	1	2		1	1	1	1				1	1
TRHE 40-140 & 190	1					1	2		1					1		1	1
TRHB 50/ GH - F - RA	1					1		1	1					1		1	1
TRHB 50/ B2 - A3	1			1	1	1	2		1					1		1	1
TRHC 80	1	1	1	1	1	1	1		1	1	1	1				1	1
TRHE 100	1			1	1	1	2		1					1		1	1

6 - MACHINING THE PUMP PARTS

Liquid ring vacuum pumps achieve their best efficiency when the tolerance between the impeller and the port plates are within certain limits: lower tolerances could lead to pump seizing while higher tolerances could result in loss of pump capacity and vacuum level.

When machining is required to refurbish the faces of the port plates, it is of the utmost importance to keep the surfaces parallel, flat and within the permissible dimensions. Do not remove more than 0.5 mm each face.

Figure 11 or 12 and table 9 illustrate the location and the recommended original clearance between each side of impeller(s) face and their respective port plates (pumps series 32 are fitted with free floating impellers that will automatically seek the centre between the two port plates).

NOTE: Upon completion of pump assembly the attained final total clearance between impeller(s) and port plates (double that of each side), could be less than the original suggested. However, this total clearance should not be less than 0.3 mm or 0.15 mm each side (0.4 total or 0.2 mm each side for pumps series TRHE 100 and TRSE 125). Lesser clearances will greatly increase the risk of pump seizing during operation (refer to equation X1 - Y1 ≥ 0.3 mm on page 8).

When machining is required, it is recommended to begin machining the sides of impeller(s) VDMA 230(.1) attaining therefore a uniform dimension “H1” (see figure 13 to 20).

Follow with machining of impeller casing(s) VDMA 110(.1) or intermediate element VDMA 140 or 140.1 to dimension “H” taking into account the required clearance and the gasket thickness that will be used between impeller centerbody(s) and casings VDMA 106 and 107, or the port plates VDMA 137(.1) (.2) (.3) (.4).

When the gasket is liquid compound, allow a thickness of about 0.05 mm, see chapter 7.2.

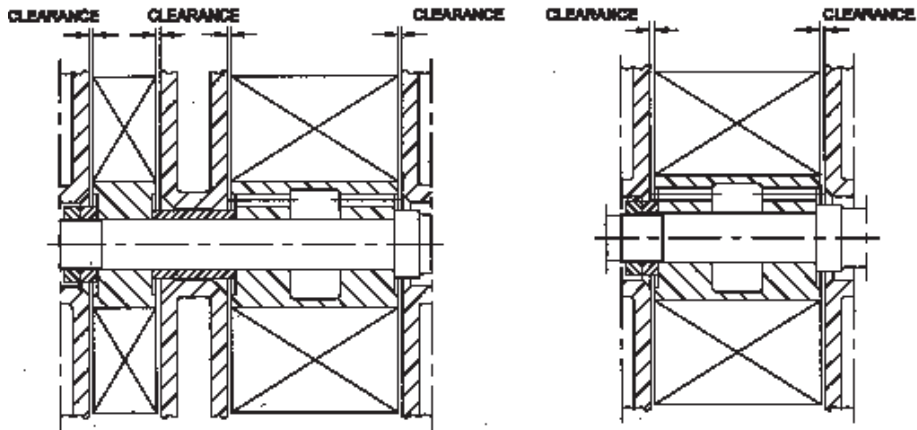

Figure 11 - Pumps series TRH

Figure 12 - Pumps series TRS - TRV

To summarize: Sum of dimension "H" and thickness of gasket material for each side equals the sum of dimension "H1" and the 2 recommended original clearances.

Then proceed with machining of port plates if required.

All these machining operations will result in a shorter pump: consequently the shaft shoulders at drive end, relative to location of mechanical seal and bearings, must be adjusted to compensate for the total material removed (see fig 21 or 22 and applicable note, for instruction on adjusting the shaft shoulders).

To lock the bearing at the pump drive end it may be required to introduce an additional spacer to the VDMA 505 that is already used as a standard.

In the event the bearing cover VDMA 360 at drive end interferes with shaft VDMA 210, machining of the bearing cover central bore will be required.

Table 9 - RECOMMENDED ORIGINAL CLEARANCES

PUMPS SERIES	PUMPS DESIGN	CLEARANCE each SIDE (mm)	CLEARANCE each IMPELLER (mm)
TRHE 32-20 to 60 TRSE 32	GH - RZ - RA - A3	0.15	0.30
TRHC 40-110 TRHE 40 -110 TRSC 40 TRSE 40	GH - F - RA A3	0.15 to 0.20	0.30 to 0.40
TRHC 40-140 & 190 TRHE 40-140 & 190	GH - F - RA	0.20 to 0.25	0.40 to 0.50
TRSC 50 TRSE 50	A3	0.25 to 0.30	0.50 to 0.60
TRHB 50	GH - F - RA A3	0.20 to 0.25 0.30 to 0.35	0.40 to 0.50 0.60 to 0.70
TRHC 80 TRSB 100 TRSC 100	GH - F - RA A3	0.25 to 0.30 0.30 to 0.40	0.50 to 0.60 0.60 to 0.80
TRHE 100 TRSE 125	GH - F - RA A3	0.40 to 0.50	0.80 to 1.00
TRVA 65	GH - F - RA A3	0.15 to 0.20 0.20 to 0.30	0.30 to 0.40 0.40 to 0.60

6.1 - TYPICAL SCHEMATICS FOR MACHINING TO RESTORE CLEARANCES PUMPS SERIES "TRH"

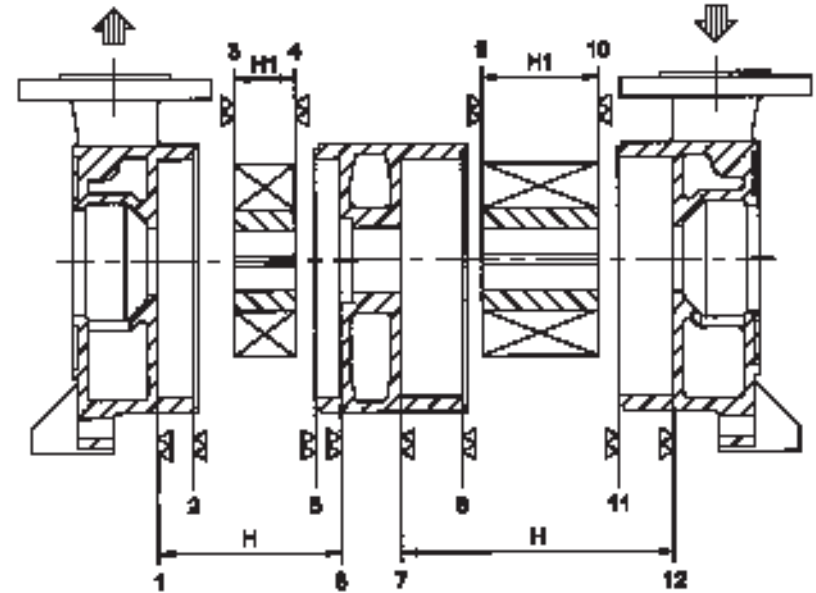

Figure 13 TRHE 32-20 to 60

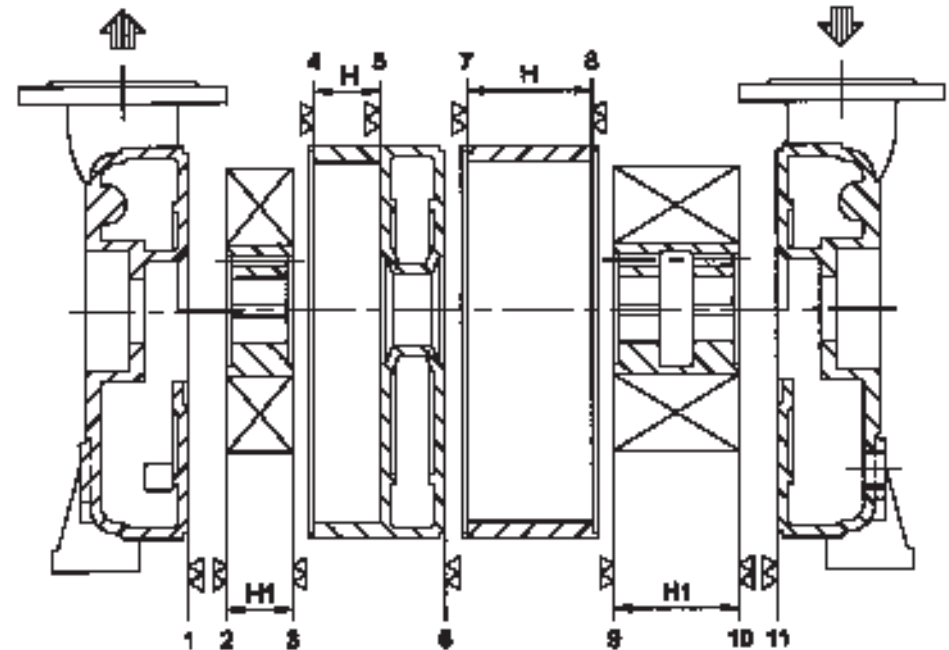

Figure 14 TRHE 40 TRHB 50/GH - F - RA

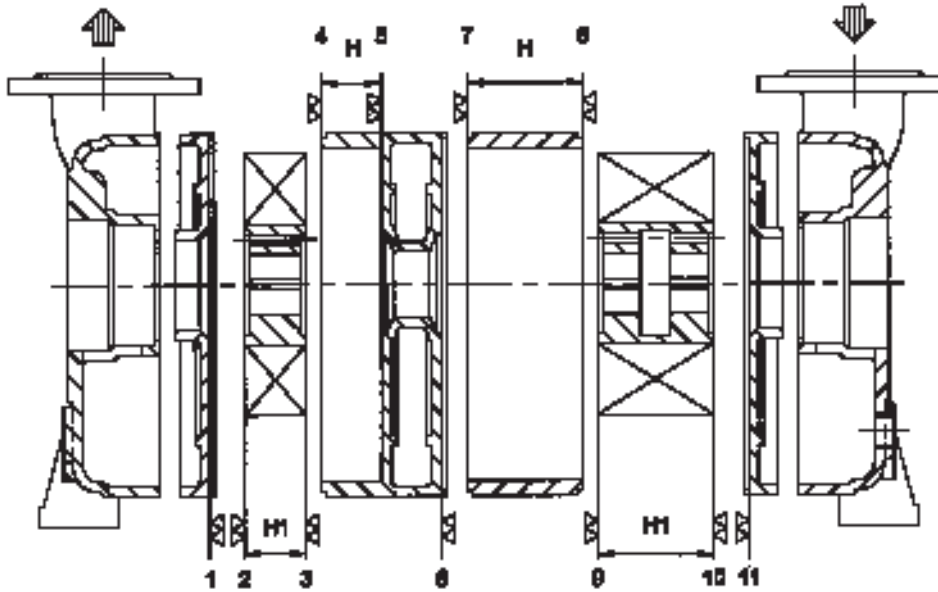

Figure 15 TRHC 40/GH - F - RA

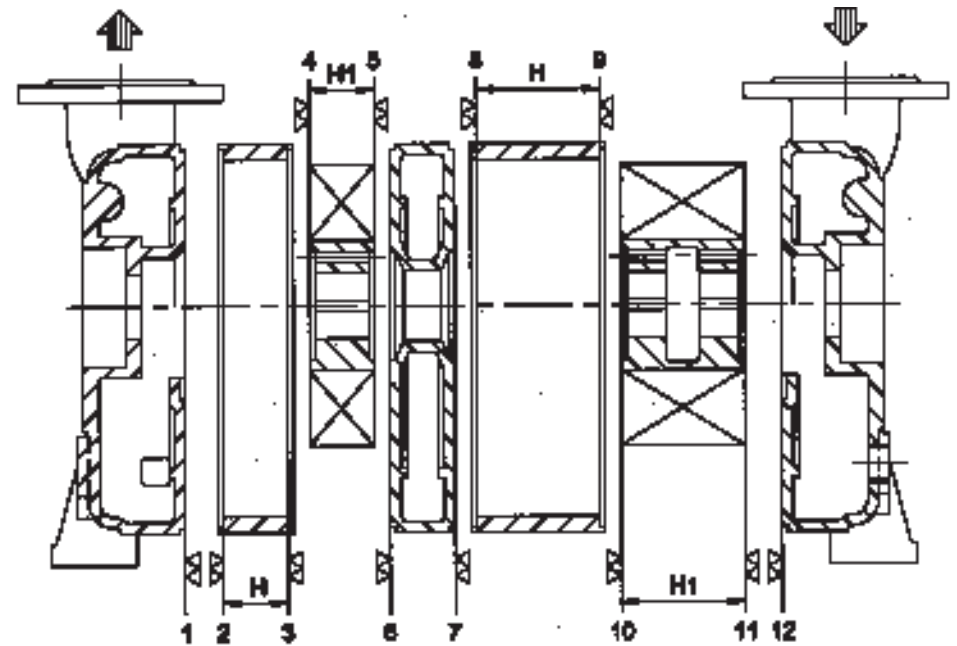

Figure 17 TRHB 50/B2 - A3 TRHE 100

6.2 - TYPICAL SCHEMATICS FOR MACHINING TO RESTORE CLEARANCES
PUMPS SERIES "TRS - TRV"

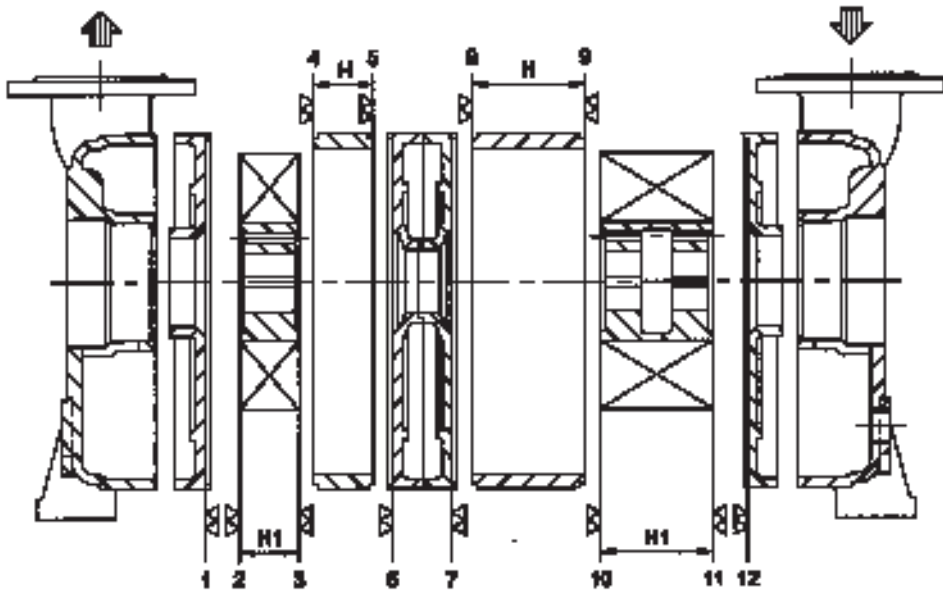

Figure 16 TRHC 40/B2 - A3 TRHC 80

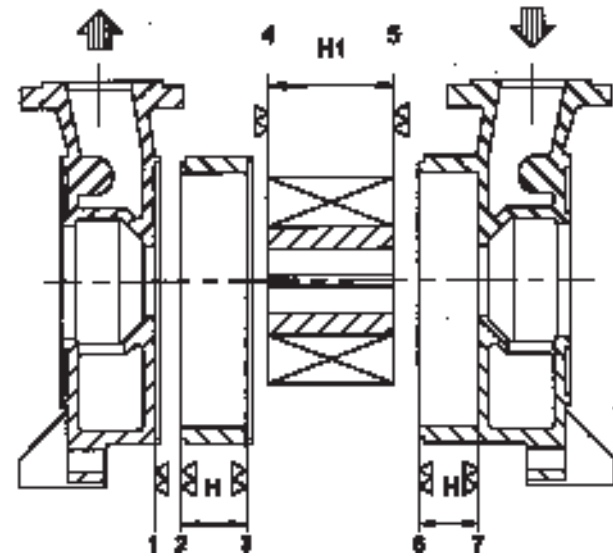

Figure 18 TRSE 32

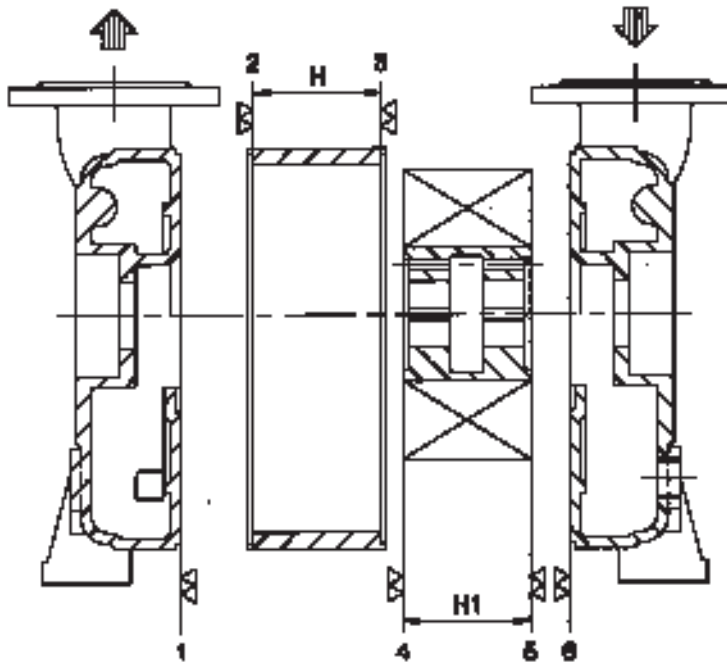

Figure 19 TRSB 100 TRSE 40 - 50 - 125

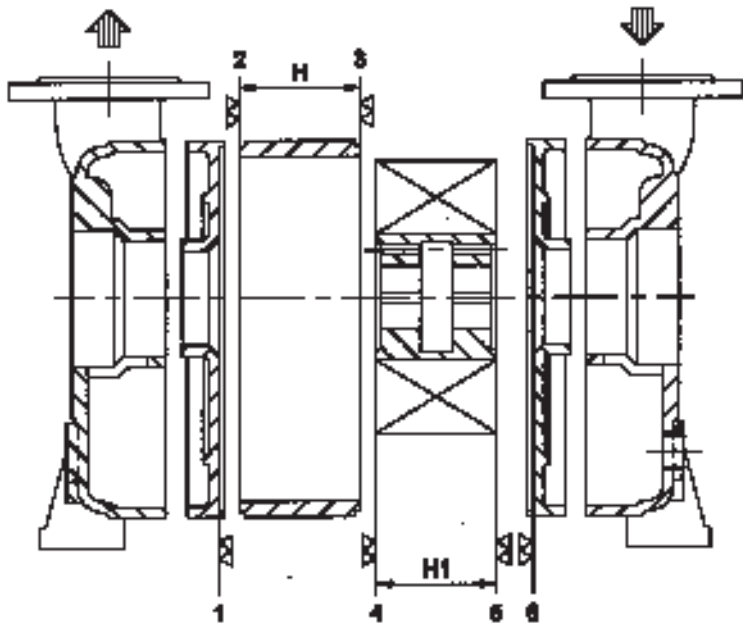

Figure 20 TRSC 40 - 50 - 100 TRVA 65

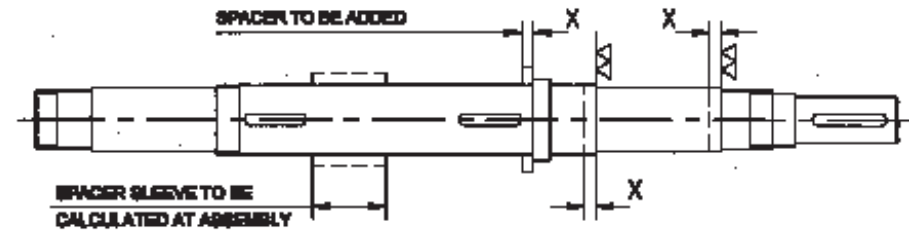

Figure 21 Pumps series "TRH" (not for series 32)

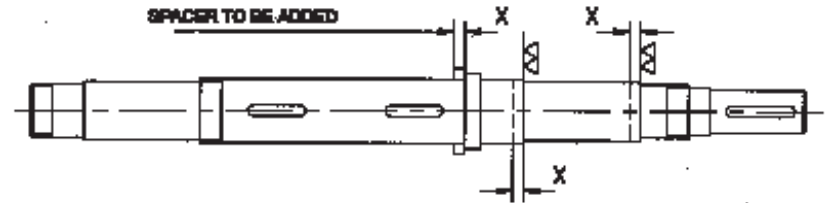

Figure 22 Pumps series "TRS-TRV" (not for series 32)

NOTE:

X = Amount of material to be removed equals the sum of material thickness removed from each side of impeller(s) and from all machined port plates. The spacer to be added has a thickness of "X" less the amount of material removed from the last surface (see fig 11 or 12 or 6 or 7).

7 - PUMP ASSEMBLY

Prior to starting the assembly operations, carefully study these instructions to become familiar with the assembly procedures, the sequence of operations and the procurement of the required tools.

7.1 - PUMPS SERIES "TRHE & TRSE 32"

Assemble the pumps following the sequences listed on table 10 and consulting the sectional drawings in chapter 10 for parts listing and location.

Table 10 - ASSEMBLY OF TOTAL PUMP

COMPONENT VDMA NO.	STEP I											STEP II										
	MECHANICAL SEAL	BEARING HOUSING	SHOULDER RING	ELASTIC RING	BEARING	CIRCLIP	BEARING COVER	CIRCLIP	GASKET	DISCHARGE CASING	SCREW	KEY	KEY	2ND STAGE IMPELLER	GASKET	IMPELLER HOUSING	INTERMEDIATE ELEMENT	GASKET	KEY	1ST STAGE IMPELLER	SUCTION CASING	TIE-BOLT
PUMP SERIES	433.1	357	505	935	320	932	365.1	932.3	400.2	107	914.1	940.1	940.2	230.1	400	110	140	400	940.1	230	106	905
TRHE 32-20 & 45	1	1	1	1	1	1	1	1	1	1	4		1	1	1		1	1	2	1	1	3
TRHE 32-60	1	1	1	1	1	1	1	1	1	1	4	1		1	1		1	1	2	1	1	3
TRSE 32	1	1	1	1	1	1	1	1	1	1	4	2			1	1		1		1	1	3

CONTINUED, NEXT PAGE

Table 10 CONTINUED - ASSEMBLY OF TOTAL PUMP

COMPONENT VDMA NO.	STEP III									STEP IV			
	MECHANICAL SEAL	GASKET	BEARING HOUSING	SCREW	SHOULDER RING	BEARING	CIRCLIP	BEARING COVER	CIRCLIP	KEY	GASKET	MANIFOLD	BOLT
PUMP SERIES	433.2	400.2	357	914.1	505	320	932	365	932.3	940	400.8	147	901.8
TRHE 32-20 & 45	1	1	1	4	1	1	1	1	1	1			
TRHE 32-60	1	1	1	4	1	1	1	1	1	1	2	1	4
TRSE 32	1	1	1	4	1	1	1	1	1	1			

- Place the shaft VDMA 210 vertically in a vice, with the drive end pointing down. Moisten the rotating part of the mechanical seal VDMA 433.1 (with soapy water, water, or other but, avoid using oils) and fit it on to the shaft. Lubricate the O-ring of stationary seal part VDMA 433.1 and press the latter into the seal housing VDMA 357. See also chapter 2.
- Clean the two faces of the mechanical seal with a soft tissue. Insert the seal housing on the shaft and hold it pushing the mechanical seal down.
- Introduce on the shaft the spacer VDMA 505 having a thickness of 2 mm. Place the wafer spring VDMA 935 in the bearing housing. Heat the bearing and fit it on the shaft pushing down until it comes to rest against the spacer. Lock the bearing on the shaft with the snap ring VDMA 932.
- Place on the bearing housing the bearing cover VDMA 365.1. With the help of a gear puller press the bearing cover and the wafer spring so that the snap ring VDMA 932.3 comes to rest in its groove, then remove the gear puller.
- Place the gasket VDMA 400.2 on the seal housing. Slide the shaft and the bearing housing (with gasket) through the discharge casing VDMA 107, secure it in place with the four Allen screws VDMA 914.1. Be sure to locate the seal housing draining hole pointing to the bottom.
- Position the pump vertically resting on the bearing housing. Fit on the shaft the key VDMA 940.1 (.2) of the impeller VDMA 230(.1), depending upon the pump type. Introduce the impeller on the shaft making sure that the orientation of the impeller blades is as indicated in schematics figure 24 or 25 for pumps with C.W. rotation. For special pumps, with C.C.W. rotation, the impeller must be mounted with the blades pointing to the left side.

NOTE: The keys must have a tight fit on the shaft key-way and precise fit on the impeller key slot, however the impeller must be free to slide over the shaft.

Place a gasket VDMA 400 on the pump discharge casing.

In the case of single stage pumps (TRSE series), the impeller centre body VDMA 110 should be placed on the discharge casing with a gasket VDMA 400 in between.

In the case of a two stage pump (TRHE series) fit the intermediate plate VDMA 140, with particular attention as not to damage the radial seal ring VDMA 421 and placing the reference marking pointing to the casing connection, then place a gasket VDMA 400 on the sealing face of the intermediate plate.

For pumps series TRHE, fit on the shaft the other keys VDMA 940.1 of the first stage impeller VDMA 230. Introduce the impeller on the shaft to set the blades as the second stage impeller VDMA 230.1.

Place the suction casing VDMA 106 on the pump.

- Introduce the three tie-bolts VDMA 905 leaving the nuts finger tight. Place the pump on a flat and horizontal table, align all the pump components and tighten the tie-bolts to 4 kgm (see table 13) using a torque wrench.
 - Ascertain that the shaft shoulder is 35.5 mm ± 0.5 mm deep relative to the external face of the suction casing VDMA 106 (see figure 1 and table 3). Lubricate the seal rotating part (with water, soapy water, etc. but not oils) and fit it on the shaft. Lubricate the O-ring on the stationary seal and press this part in the seal housing VDMA 357.
- NOTE:** The seal housing for the drive end side should have threaded holes suitable for the motor lantern, if required.
- Clean the two seal faces with a soft tissue, place a gasket VDMA 400 on the seal housing and fit this on to the suction casing VDMA 106 with the draining hole located at the bottom.
- Lock the assembly with 4 screws VDMA 914.1.
- Introduce on the shaft the 2 mm spacer VDMA 505. Fit the heated bearing VDMA 320 on the shaft until it rests against the spacer. Place the snap ring VDMA 932 on the shaft. Install the bearing cover VDMA 365 securing it with the snap ring VDMA 932.3. Fit the coupling key VDMA 940 on the shaft drive end.
- In the event the pump requires the manifold VDMA 147, mount this on to the flanges of the suction casing VDMA 106 and discharge casing VDMA 107, with gaskets VDMA 400.8 between the flanges. Secure with flange bolting VDMA 901.8.
- Rotate the pump shaft by hand to ascertain that it rotates free without internal metal contact.
- Test the pump to a hydrostatic pressure of 4 bar to verify that there are no leaks.

7.2 - PUMPS SERIES “TRH 40 to 100 - TRS 40 to 125 - TRV 65”

To begin assembling the pump series TRH, find first the length of the spacer sleeve VDMA 521 to be fitted between the two impellers (see figure 23).

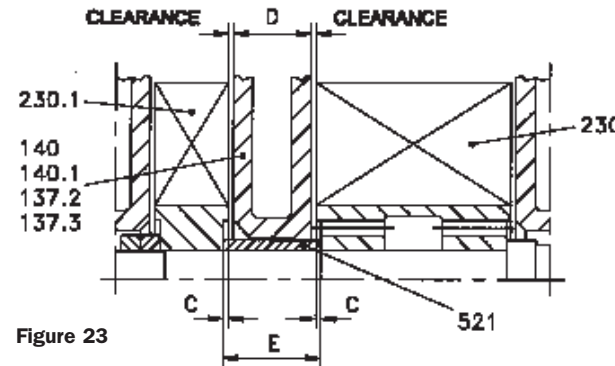

Figure 23

For pump series TRH, always measure: The “C” dimensions (when applicable) of the recessed hub for impellers VDMA 230 and 230.1, the width “D” of the intermediate element VDMA 140 or 140.1 or the width of the port plates VDMA 137.2 and 137.3 plus the thickness of the sealing liquid which will be placed between them.

The total sum of “C” dimensions (when applicable) plus the “D” dimension plus the two clearances provided for the type of pump that is being assembled (see table 9) will give the required length “E” of the impeller spacer sleeve VDMA 521. Should this be higher the sleeve must be machined, if it is lower, adjusting spacers shall be added.

For all pumps series, place the shaft VDMA 210 with the inserted keys VDMA 940.1 horizontally in a vice, fit the spacer to recover the machining operations car-

ried out on the impellers VDMA 230 (and 230.1 for pumps series TRH) and make sure that they fit perfectly, otherwise provide adjustment.

WARNING: Before inserting the impellers on the shaft, note that the direction of the blades for the pumps with clockwise rotation should be as per drawings on figure 24 or 25 (for the counter clockwise rotation, reverse the orientation of the impeller blades).

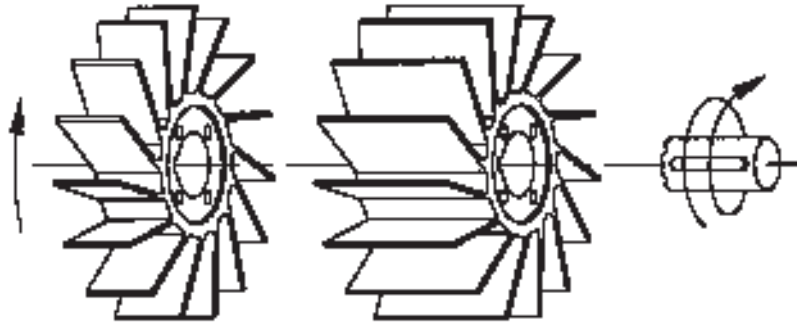

Figure 24 - Pumps series TRH

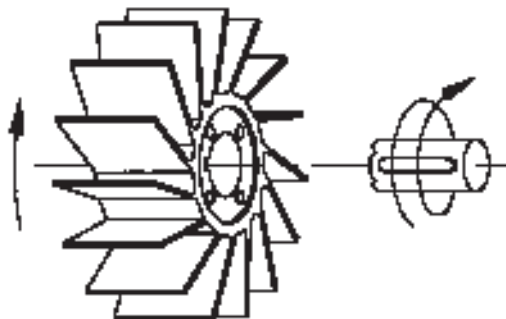

Figure 25 - Pumps series TRS - TRV

Whenever required, liquid compound to be used as gasket for metallic surfaces should be procured.

The sealing liquid commonly used and available from our stock is “LOCTITE 510 Superrapido” and is available in 50 ml cans.

NOTE: It is recommended to carry out a preliminary assembly without liquid gasket, of those pump parts included between the two casings to verify the clearances obtained are adequate.

The information given below is for reference purpose, for more detailed and precise information (on gaskets, small items and quantities) see table 11 or 12. For pump series TRH, remove the smaller impeller VDMA 230.1 and its key, insert the impeller spacer sleeve VDMA 521, the intermediate element VDMA 140 or 140.1 or the port plates VDMA 137.2 and 137.3 (WARNING: lock them with three clamps to prevent them from separating), insert the key and place the impeller VDMA 230.1, lock the assembly with the impeller nut(s) VDMA 922 or 922.1 (see figure 26 or 27).

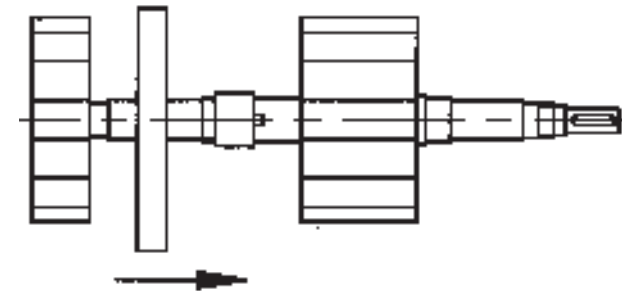

Figure 26 - Pumps series TRH (step I)

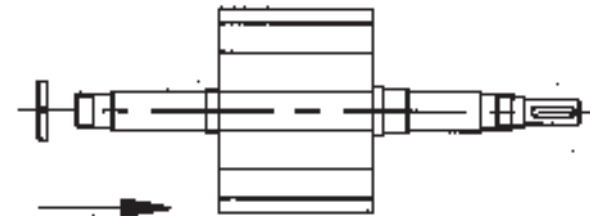

Figure 27 - Pumps series TRS - TRV (step I)

Place the suction casing VDMA 106 (complete with port plate VDMA 137.1 if required) in the horizontal position, resting on a stand similar to that shown on figure 28 to 31 (section of heavy duty pipe or similar stand).

Assemble the impeller casing VDMA 110 (or, when provided, the two impeller casings that form the first stage) with the references markings on the casting, in line with the axis of the inlet casing.

Remove the shaft from the vice together with the impeller(s) and the intermediate plate(s), insert it into the suction casing, using (for heavier assemblies) a threaded hook screwed on the non-drive end of the shaft, see figure 28 or 30.

Continue the assembly operations following the instructions given on figure 29 or 31 and table 11 or 12: to help with the identification and the location of each component, see also the sectional drawings on chapter 10.

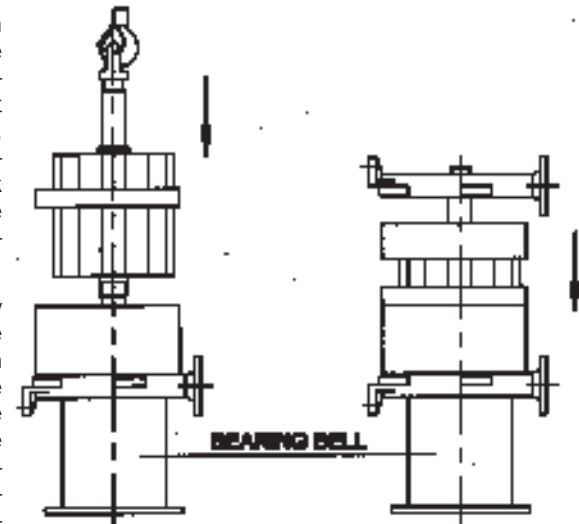

Figure 28 and 29 - Pumps series TRH (step II & III)

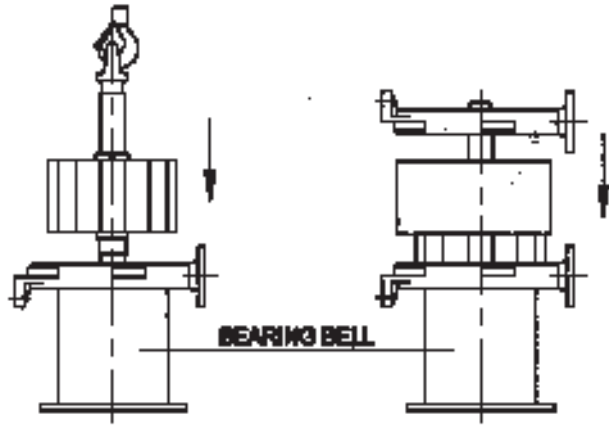

Figure 30 and 31 - Pumps series TRS - TRV (step II & III)

Table 11 - ASSEMBLY OF TOTAL PUMP - PUMPS SERIES "TRH"

COMPONENT VDMA NO.	STEP I										STEP II						
	1ST STAGE IMPELLER	SPACER SLEEVE	INTERMEDIATE ELEMENT		PORT PLATE	PIN	PORT PLATE	2ND STAGE IMPELLER	SPACER SLEEVE	NUT		SUCTION CASING	PIN	PORT PLATE	GASKET	IMPELLER CASING	GASKET
PUMP SERIES	230	521	140	140.1	137.2	561	137.3	230.1	525	922	922.1	106	561	137.1	400	110	400
TRHC 40-110/ GH - F - RA	1	1	1				1	1	1	1	1	1	1	1	1	1	1
TRHC 40-110/ B2 - A3	1	1			1	1	1	1	1	2		1	1	1	1	1	1
TRHE 40-110	1	1	1				1			2		1			1	1	1
TRHC 40- 140 & 190/ GH - F - RA	1	1	1				1	1		1	1	1	1	1	1	1	1
TRHC 40- 140 & 190/ B2 - A3	1	1			1	1	1	1	1	2		1	1	1	1	1	1
TRHE 40- 140 & 190	1	1	1				1			2		1			1	1	1
TRHB 50/ GH - F - RA	1	1		1			1			1	1			1	1	1	1
TRHB 50/ B2 - A3	1	1	1				1			2		1		1	1	1	1
TRHC 80	1	1			1	1	1	1	1	1	1	1	1	1	1	1	1
TRHE 100	1	1	1				1			2		1			1	2	2

CONTINUED ON NEXT PAGE

Table 11 CONTINUED - ASSEMBLY OF TOTAL PUMP - PUMPS SERIES "TRH"

COMPONENT VDMA NO.	STEP III						STEP IV			
	GASKET	IMPELLER CASING	GASKET	PORT PLATE	PIN	DISCHARGE CASING	TIE-BOLT	GASKET	MANIFOLD	BOLT
PUMP SERIES	400	110.1	400	137.4	561	107	905	400.8	147	901.8
TRHC 40-110/ GH - F - RA			1	1	1	1	4			
TRHC 40-110/ B2 - A3	1	1	1	1	1	1	4			
TRHE 40-110			1			1	4			
TRHC 40- 140 & 190/ GH - F - RA			1	1	1	1	4	2	1	8
TRHC 40- 140 & 190/ B2 - A3	1	1	1	1	1	1	4	2	1	8
TRHE 40- 140 & 190			1			1	4	2	1	8
TRHB 50/ GH - F - RA			1			1	5	2	1	8
TRHB 50/ B2 - A3	1	1	1			1	5	2	1	8
TRHC 80	1	1	1	1	1	1	5	2	1	8
TRHE 100	1	1	1			1	7	2	1	16

Table 12 - ASSEMBLY OF TOTAL PUMP - PUMPS SERIES "TRS - TRV"

COMPONENT VDMA NO.	STEP I			STEP II			STEP III					STEP IV						
	IMPELLER	SPACER SLEEVE	NUT	SUCTION CASING	PIN	PORT PLATE	GASKET	IMPELLER CASING	GASKET	PORT PLATE	PIN	DISCHARGE CASING	TIE-BOLT	GASKET	MANIFOLD	BOLT		
PUMP SERIES	230	525	922	922.1	106	561	137.1	400	110	110.1	400	137.4	561	107	905	400.8	147	901.8
TRSC 40- 55 ÷ 100	1	1		1	1	1	1	1	1		1	1	1	1	4			
TRSC 40- 150	1	1		1	1	1	1	1	1		1	1	1	1	4	2	1	8
TRSE 40	1		2		1		1	1	1		1	1	1	1	4			
TRSC 50	1	1		1	1	1	1	1	1		1	1	1	1	4	4	2	16
TRSE 50	1		2		1		1	1	1		1	1	1	1	4	4	2	16
TRSB 100	1	2	1	1	1	1	2	1	7	4	2	16						
TRSC 100	1		1		1	1	1	1	1		1	1	1	1	5	4	2	16
TRSE 125	1		2		1		1	1	1	2			1	7	4	2	32	
TRVA 65	1		2		1	1	1	1	1		1	1	1	5	4	2	16	

Now that the discharge casing VDMA 107 is in place, insert the tie-bolts VDMA 905 tightening them lightly, place the pump in the horizontal position on a flat table and align the casings.

Then tighten the tie-bolts with a torque wrench (see table 13 for the required load). Make sure that the impeller clearances within the housing are correct. Check this by measuring the shaft travel when pushed first to one direction and then to the other and dividing this value by 2 (see table 9).

If the clearance is not at least 0.15 mm each side, disassemble the pump and check all components until the error is found; the required clearances must be rebuilt as given in chapter 6, then assemble the pump again following the instructions given above.

Now assemble the mechanical seals (see chapter 2) and the bearings (see chapter 3) as it is indicated on figure 32 or 33.

Assemble the manifold(s) VDMA 147 (when provided) with the corresponding gaskets VDMA 400.8 and bolts VDMA 901.8.

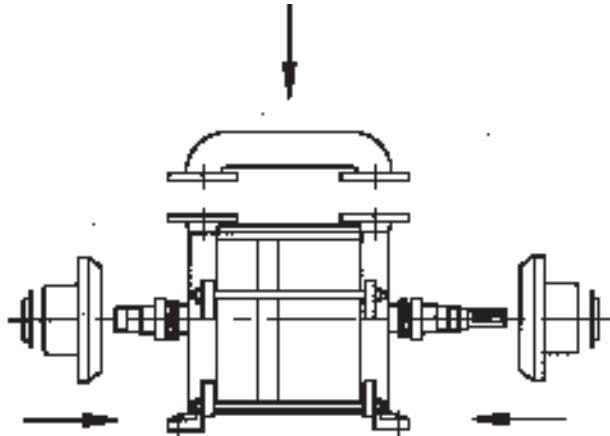

Rotate the shaft by hand making certain that there is no internal metal to metal contact and the rotor rotates freely.

Test the pump to a hydrostatic pressure of 4 bar to verify that there are no leaks.

Figure 32 - Pumps series TRH (step IV)

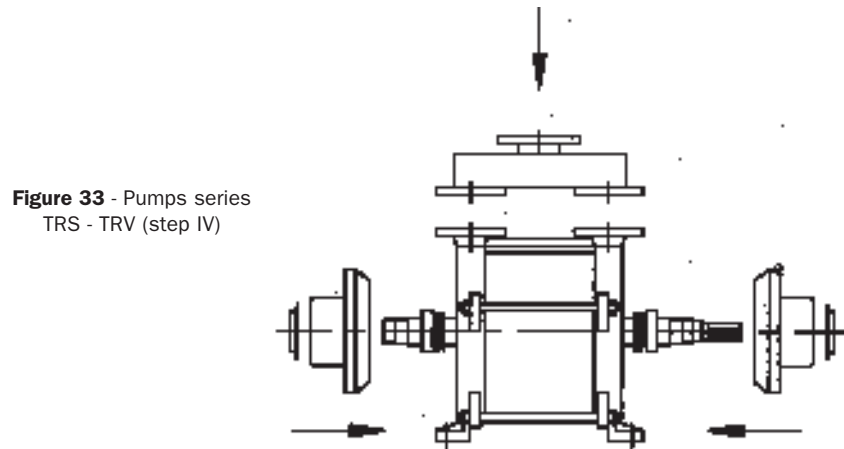

Figure 33 - Pumps series TRS - TRV (step IV)

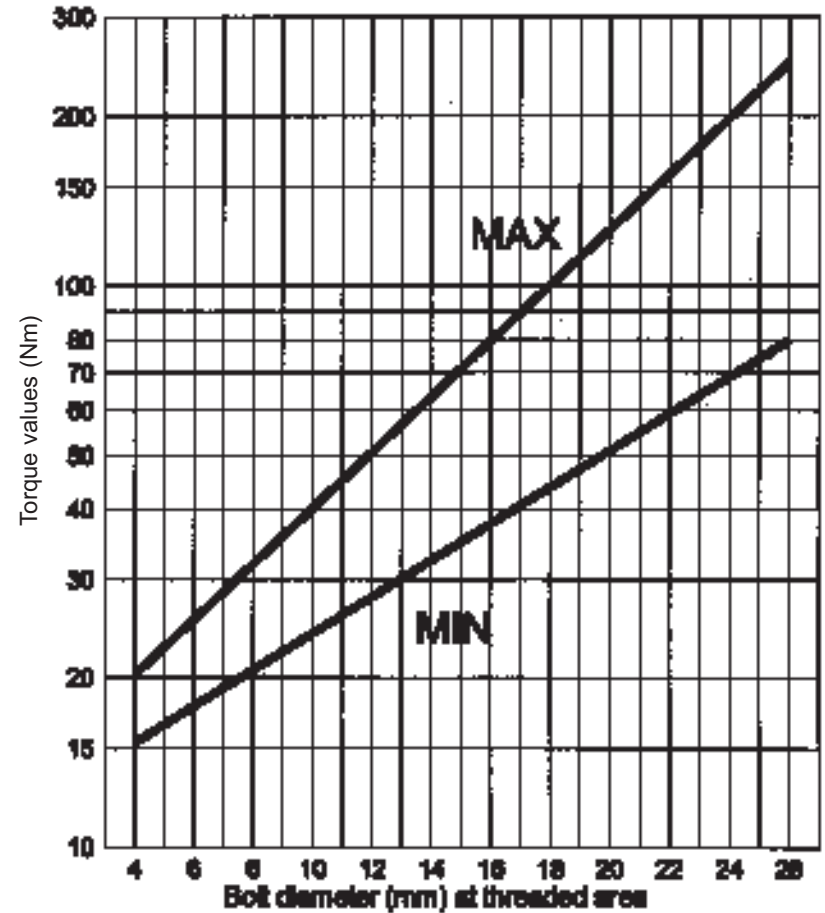

Figure 34 TORQUE VALUES FOR VARIOUS BOLT SIZES

Table 13 TIE-BOLTS TORQUE VALUES

PUMPS SERIES	TIE-BOLTS		TORQUE VALUES	
	Ø	Quantity	kgm	Nm
TRHE 32-20 to 60 TRSE 32	12	3	4	39.2
TRHE 40-110 TRSE 40			5	49
TRHC 40 TRHE 40-140 & 190 TRSC 40 TRSC 50 TRSE 50	14	4	6	58.8
TRVA 65			6.5	63.7
TRHB 50 TRHC 80 TRSC 100 TRSB 100	16	5	8	78.5
TRHE 100 TRSE 125			18	176.5

8 - RECOMMENDED SPARE PARTS

When ordering the pump it is good practice to also order the necessary spare parts, especially when there are no stand-by pumps in the installation. This will minimise unnecessary down times in the event of pump failures or routine maintenance.

It is therefore, recommended to stock the following spare parts for each pump size:

- 1 Impeller set
- 1 Port plates set
- 1 Complete shaft assembly
- 1 Bearing set
- 1 Mechanical seal set
- 2 Gasket sets
- 1 Gasket sealing liquid
- 1 Bearing spacer ring set
- 1 Coupling insert set

For better parts management, the VDMA 24296 standards suggest to stock the number of parts as a function of the number of pumps being used in the plant.

On the pump nameplate are printed pump model, year of manufacture and pump serial number. When ordering spare parts always provide this information.

Pump type, parts item number (VDMA) and description, as per the parts list on chapter 9 and pump sectional drawings on chapter 10, is useful information that helps to supply correct spare parts for your pump.

We recommend the use of original parts: in case of deviation, Travaini Pumps USA declines any responsibility for eventual damages caused by non original spare parts.

9 - PARTS LIST

VDMA No.	COMPONENT
106	Suction casing
542	Seal bush
107	Discharge casing
561	Cylinder pin
110...	Impeller casing
636	Greaser
137...	Port plate
672	Anti-cavitation valve
140...	Intermediate element
701	Pipe
147	Manifold
723...	Companion flange
180.5	Valve plate
731...	Fitting
210	Shaft
734	Nipple
230...	Impeller
735	Nipple
320	Ball bearing
901...	Screw
357	Bearing and mechanical seal housing
901.8	Bolt
360...	Bearing cover
902...	Stud
365...	Bearing cover
903...	Plug
400...	Gasket
904.1	Grub screw
400.9	Flat valve
905	Tie-bolt
421...	Radial seal ring
914...	Screw
433...	Mechanical seal
922...	Nut
461.1	Gland packing
923	Nut
485...	Mechanical seal ring
932...	Circlip
505...	Shoulder ring
935	Elastic ring
521	Impeller spacer sleeve
940...	Key 525 Spacer sleeve
554.3	Lock washer
554...	Washer Z Liquid supply inlet

TRHE 32-20 & 45

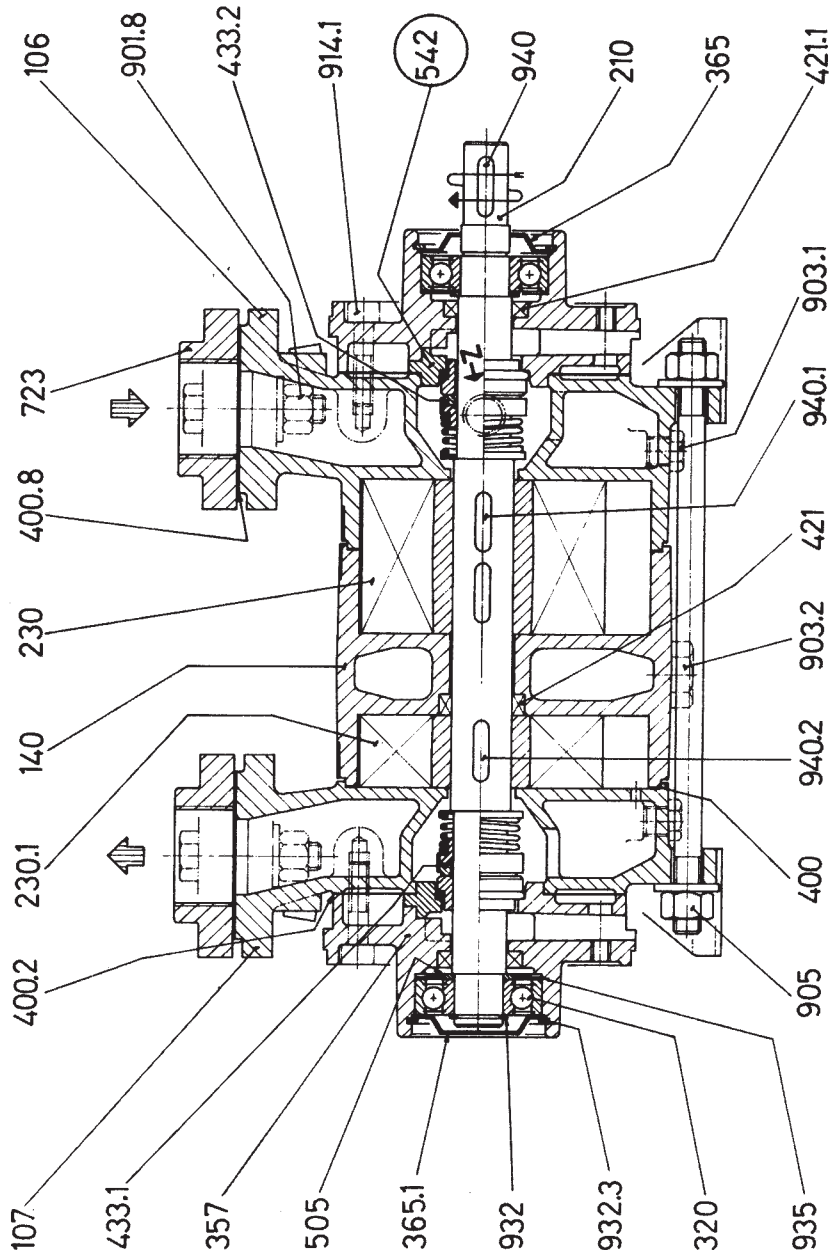

TRHE 32-60

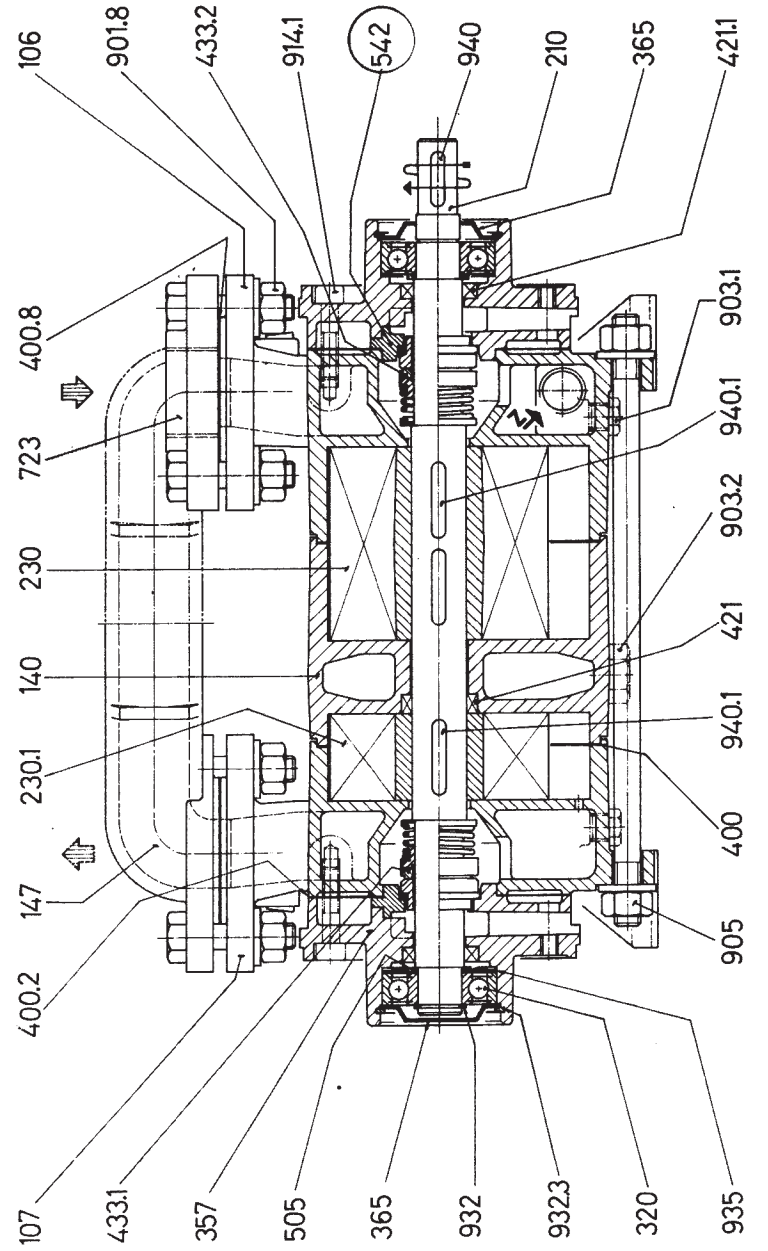

TRSE 32

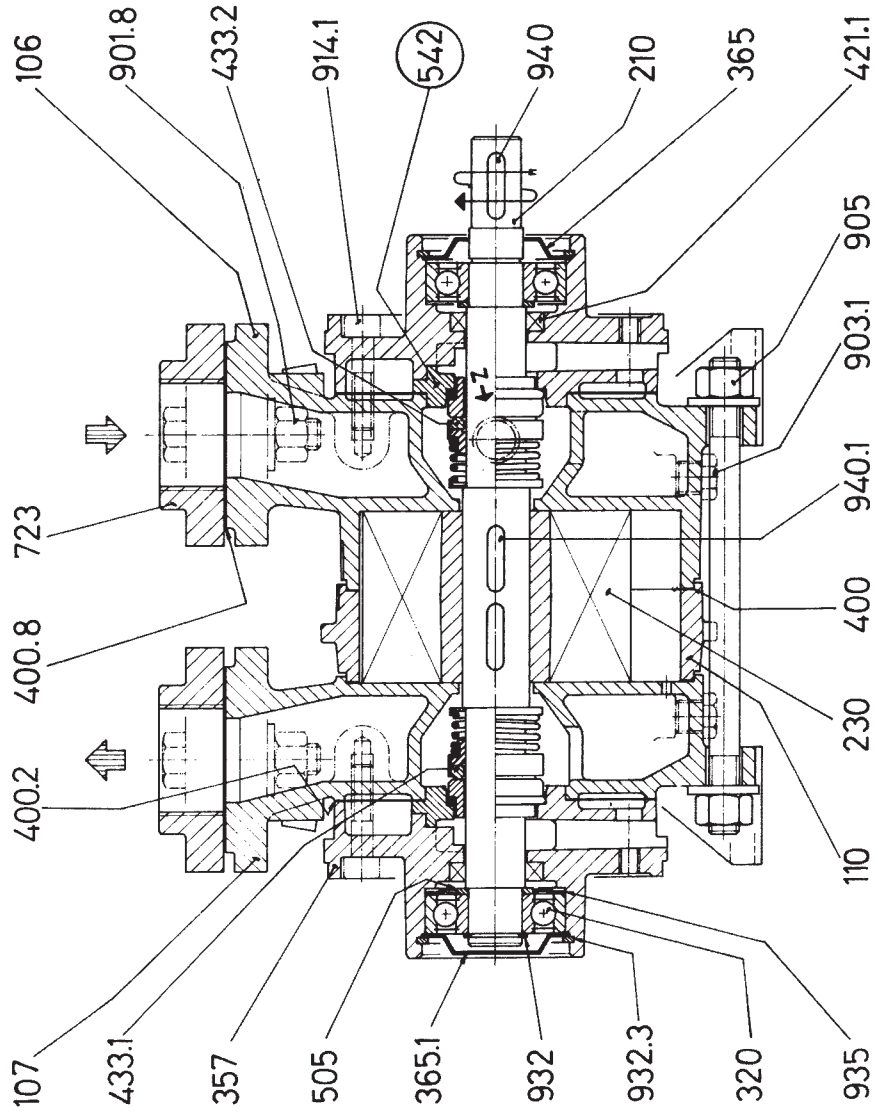

TRHC 40-110

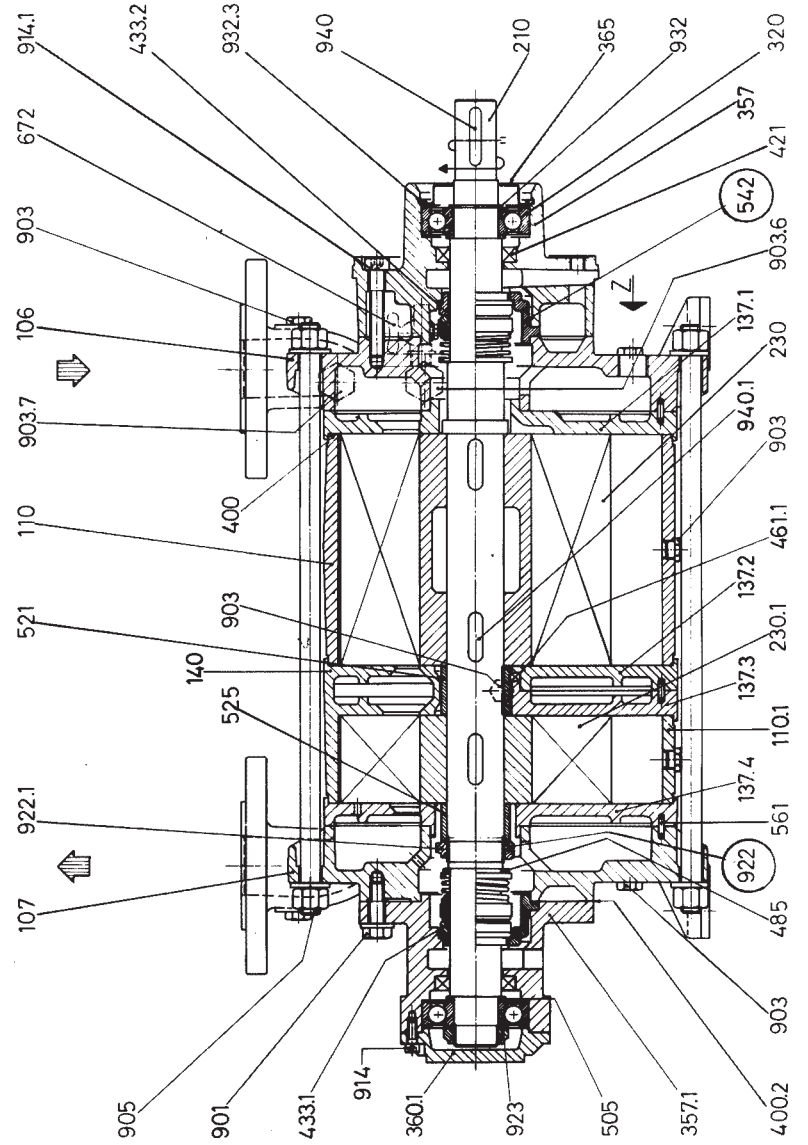

TRSE 40

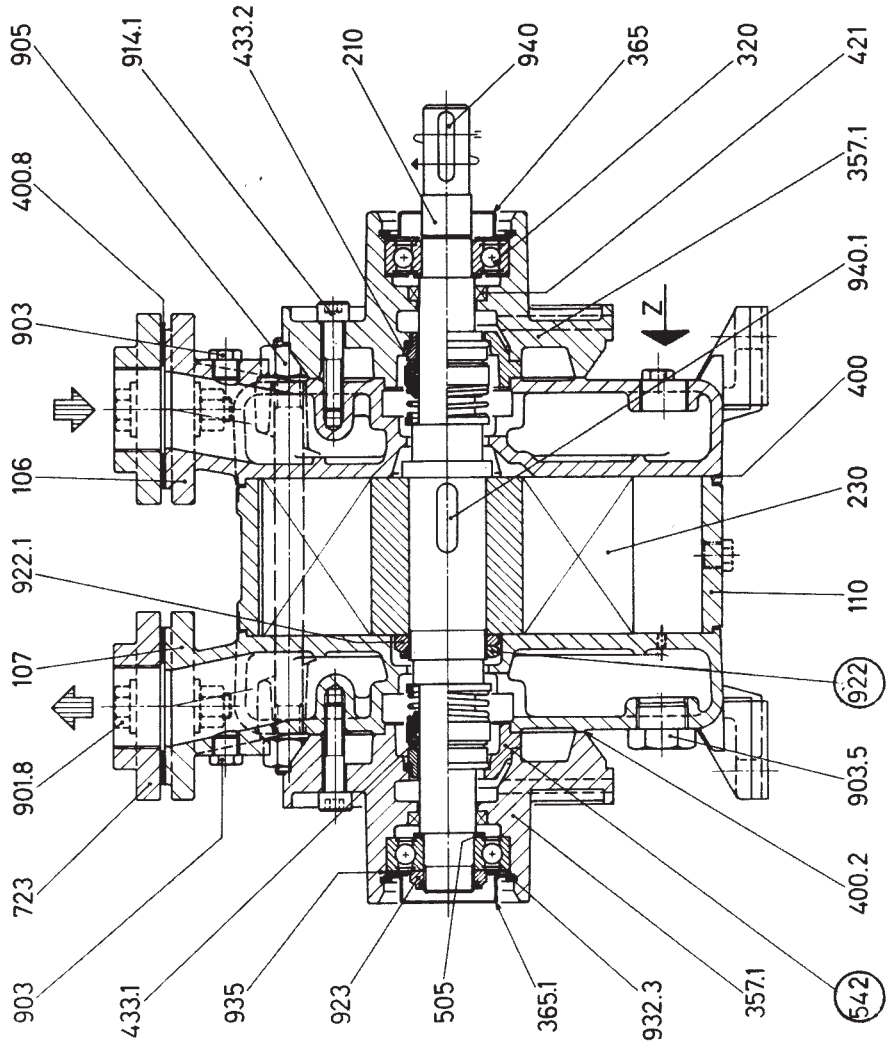

TRHC 40-140 & 190

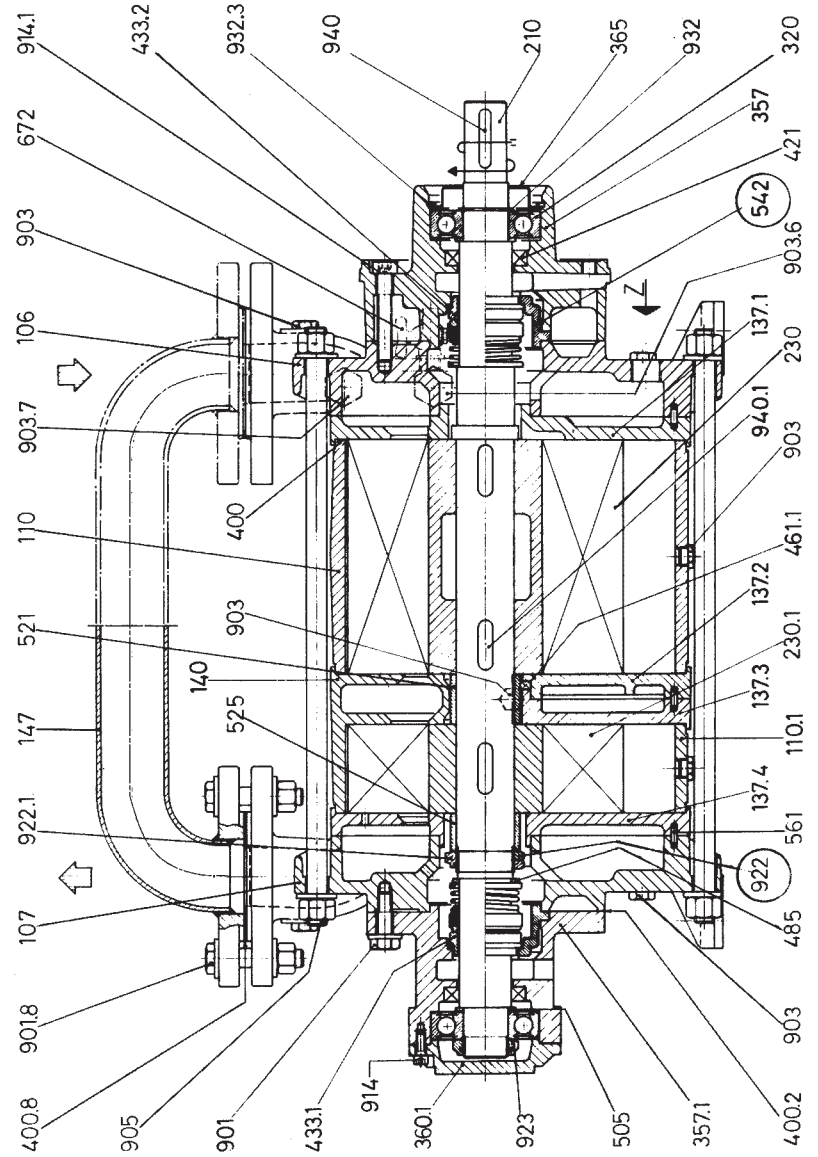

TRSB 100

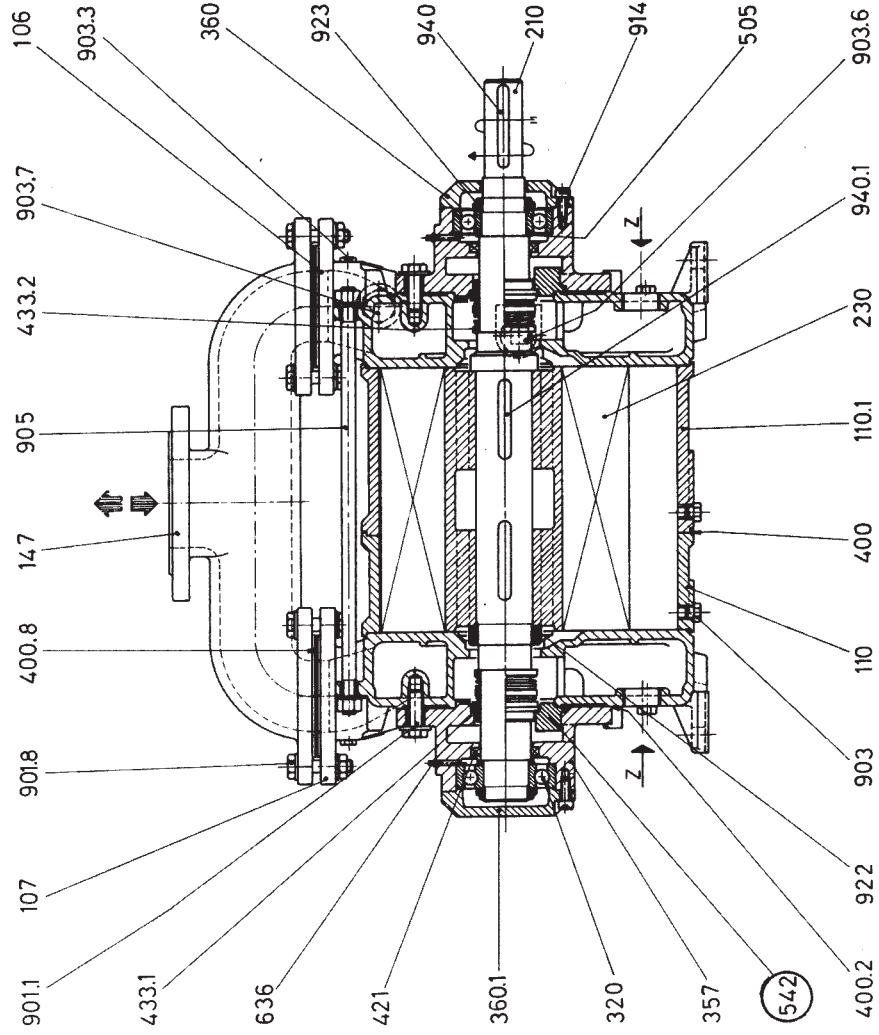

TRHC 80

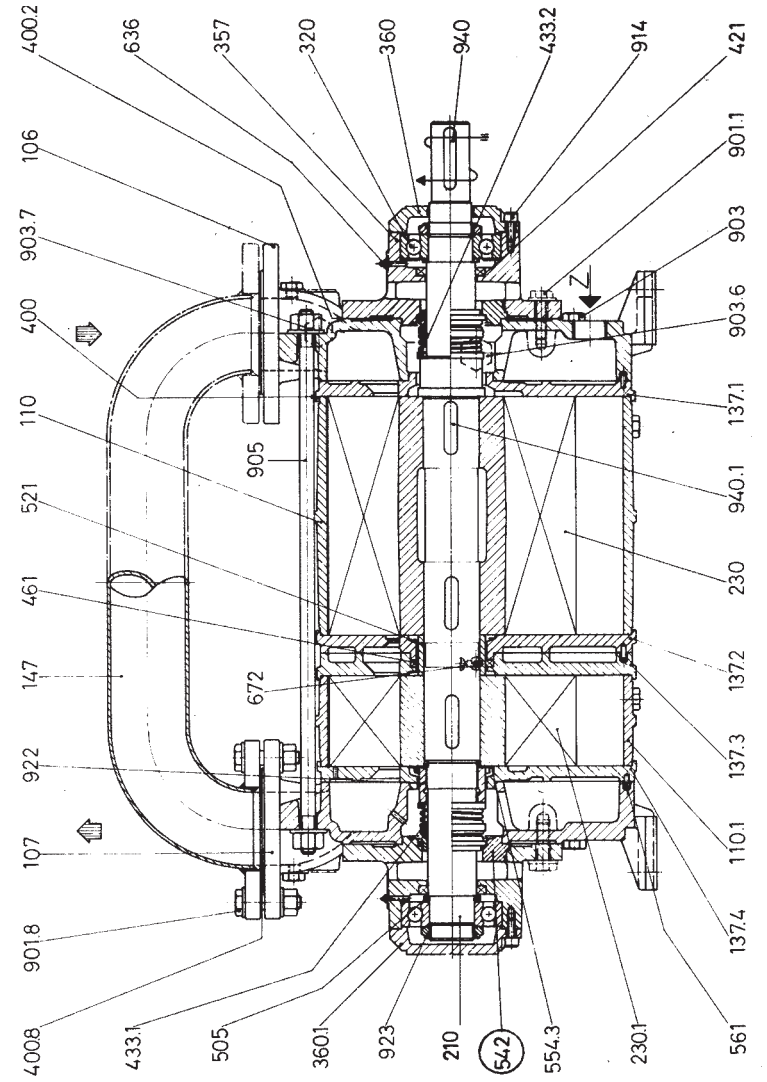

TRSE 125

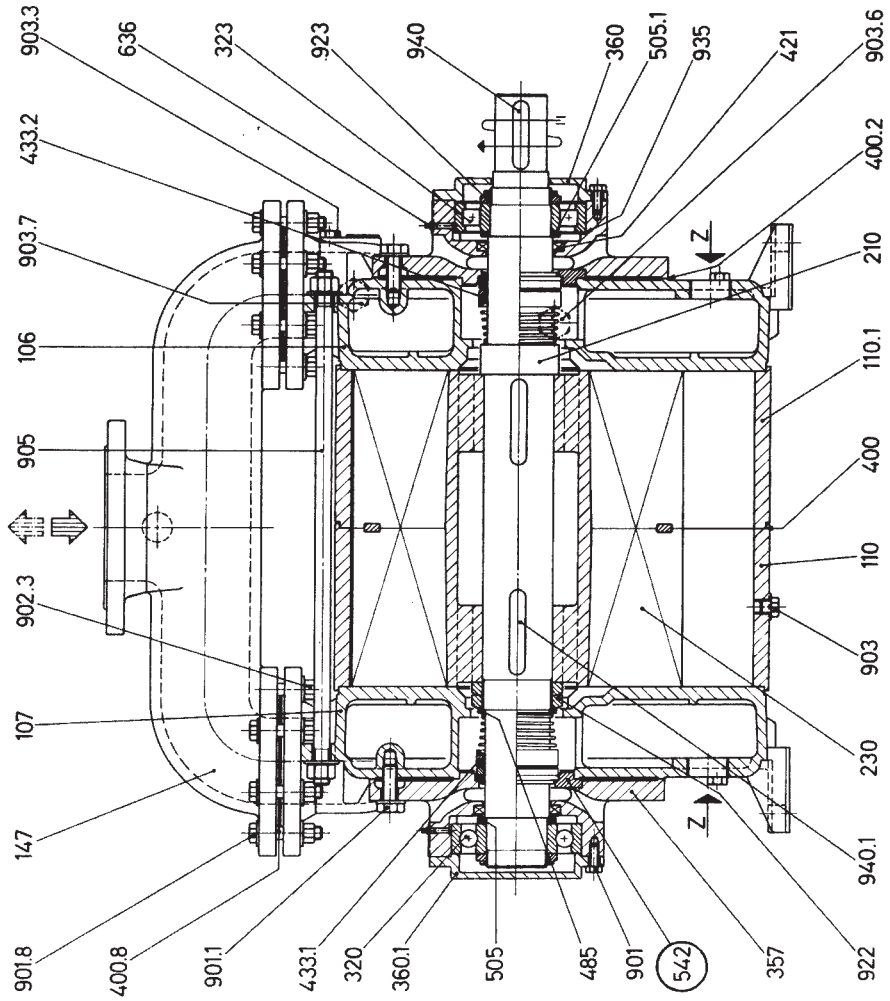

10 - TYPICAL SECTIONAL DRAWINGS

TRVA 65

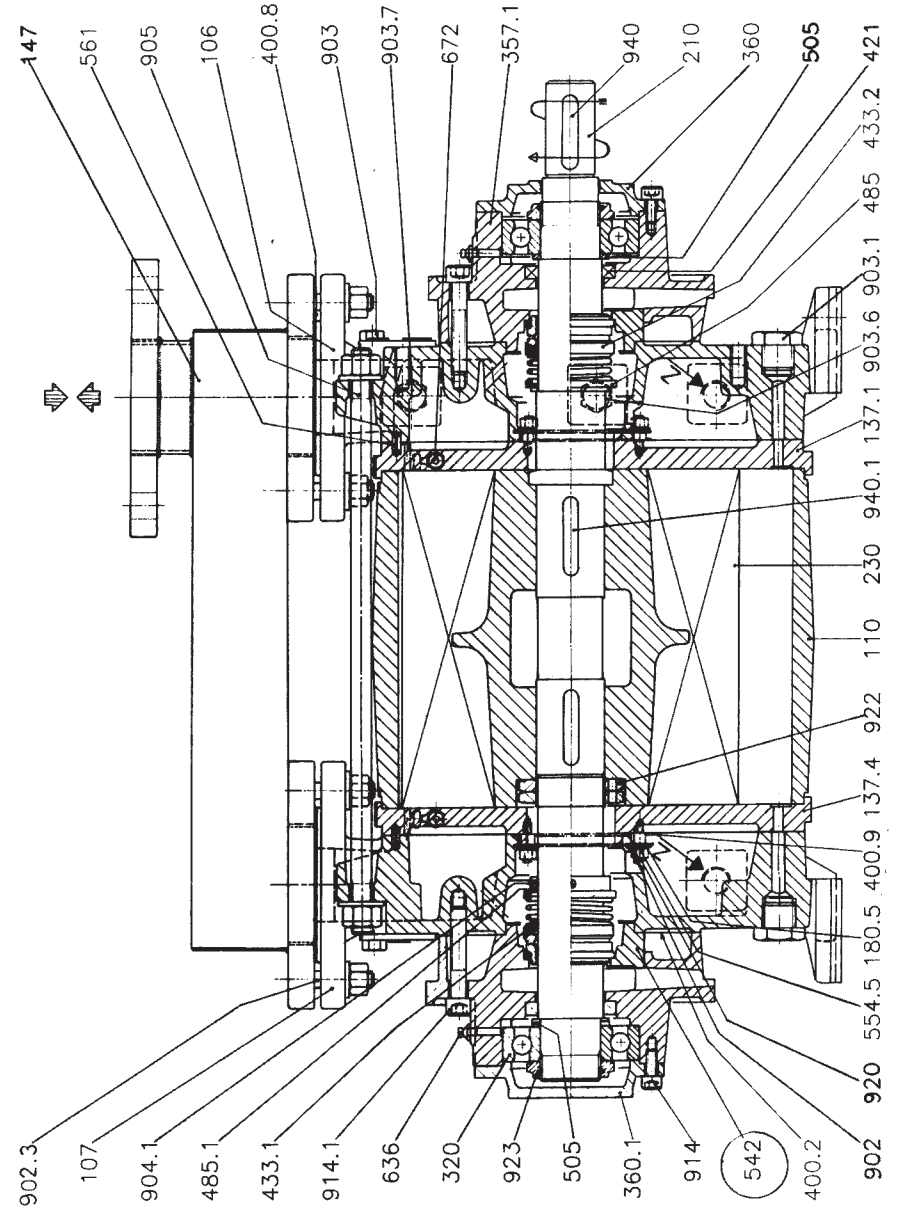

SECTION TWO: TRMB AND TRVB

INTRODUCTION

These instructions are for the maintenance staff in case of repair for the following pumps:

TRMB 25-30 & 25-60
TRMB 32-50 & 32-75
TRMB & TRVB 40-110/40-150/40-200
TRMB & TRVB 50-300

These instructions are supplied together with the manual of “INSTALLATION, OPERATION AND MAINTENANCE INSTRUCTIONS FOR LIQUID RING VACUUM PUMPS”.

They provide a reference for safe operation, installation, maintenance and repairing of the pumps.

Prior to working on the pump it is recommended to follow the instructions of safety listed in chapters 12 and 15 of the above manual, as well as absolutely important to:

- wear safety clothing, hard hat, safety shoes, safety eye glasses
- disconnect the electrical power
- close suction valves and service liquid valves
- remove pump from installation without damaging other system components
- assume all safety measures if pump has been handling dangerous fluids
- drain pump casings through the draining connections and flush the pump with clean liquid, if required.

The pump type and part number are stamped on the pump nameplate, it is always required to refer to this number when ordering spare parts or when requesting further technical information.

Assembly and disassembly requires a particular knowledge of the operations to be carried out: therefore, please read these instructions carefully and if the information given is not sufficient and/or easily understandable, it is recommended to send the pump to Travaini Pumps USA or its closest authorized representative.

Any pump repairs and/or system work carried out by others will not be guaranteed by Travaini Pumps USA.

NOTE: VDMA numbers identify all pump components. Refer to parts list in chapter 14 and to the section drawings in chapter 15.

All drawings are schematic only and are not certified for construction.

For further information please consult Travaini Pumps USA or its closest representative.

Torque values for various bolt sizes and tie-bolts are listed on figure 39.

11 - PUMP DISASSEMBLY

11.1 – DISASSEMBLY OF PUMP SERIES “TRMB”

Remove the screws VDMA 914, remove the pump casing VDMA 101 from the rest of the pump.

Remove the screws VDMA 914.1 that hold the metal cover VDMA 180.6 on the inspection port of the pump casing (for pump series “25” remove threaded plug VDMA 903.1).

Check that the components of the special valve VDMA 180.5 and Teflon flapper VDMA 400.9 are in good working conditions.

Verify that the internals of suction/discharge casing VDMA 101 are free of defects (wear, corrosion, cracks, etc.).

Remove the locking nut(s) VDMA 920 or 922 or the shaft nut(s) VDMA 923 or 923.1.

Remove the impeller VDMA 230 from the shaft and verify that the impeller is also free from defects and wear.

Remove the shaft key VDMA 940.1 and the spacer VDMA 485.

Remove the rear casing VDMA 120 from the electric motor VDMA 801 by removing the screws VDMA 901.1 or 914.2. The rotating part of the mechanical seal VDMA 433.2 will also slide out of the shaft.

The stationary part of the mechanical seal can now be pushed out of the back cover.

For pump series “32”, be sure to check the integrity of the thread locking ring Elicel (self-locking insert) that is inserted in the axial threaded bore of the motor shaft.

Proceed with the inspection of all components, replace bad and/or worn put parts with Travaini Pumps USA original parts.

It is good practice to replace, as a minimum, all wear parts such as mechanical seal, gaskets, etc.

11.2 – DISASSEMBLY OF PUMP SERIES “TRVB”

After the pump/motor assembly has been removed from the installation, remove the electric motor from the pump, if required.

The motor can be removed by removing the bolts VDMA 901.8 and VDMA 901.2. The coupling guard VDMA 685 can be removed thereafter.

Remove the screws VDMA 914 and remove the pump casing VDMA 101 from the rest of the pump

Remove the impeller nut(s) VDMA 922 or 923 while holding the impeller VDMA 230, remove the impeller from the shaft VDMA 210.

Remove the shaft key VDMA 940.1 and the spacer VDMA 485.

Remove the rotating part of the mechanical seal VDMA 433.2 from the shaft VDMA 210 and the stationary seal part from the bearing frame VDMA 330 or 353.

To disassemble the bearing frame, remove the screws VDMA 914.3 and, while applying a slight pressure, push the shaft VDMA 210 out of the bearing frame VDMA 330 or 353 toward the drive end.

With a gear puller remove the half coupling from the shaft end and remove then the coupling key VDMA 940 from the shaft.

Remove the thrower VDMA 907, the circlip VDMA 932.2 and the shoulder ring VDMA 505.2.

Remove the seal cover VDMA 360 and the elastic ring VDMA 935. Remove the V-ring VDMA 411.

Secure the shaft in a vise and remove the bearing nut VDMA 923, then remove the circlip VDMA 932.

With the help of a gear puller, remove the ball bearings VDMA 320 and 320.1.

Proceed with the inspection of all components, replace bad and/or worn out parts with TRAVAINI PUMPS USA's original parts.

It is good practice to replace, as a minimum, all wear parts such as mechanical seal, bearings, gaskets, etc.

12 - PUMP ASSEMBLY

12.1 – ASSEMBLY OF PUMP SERIES "TRMB"

Start the pump assembly by inserting the stationary part of the mechanical seal VDMA 433.2 in the rear casing VDMA 120.

Lubricate the seal O-Ring with compatible liquid, (mechanical seal dimensions are listed in table 14, see figure 35 or 36).

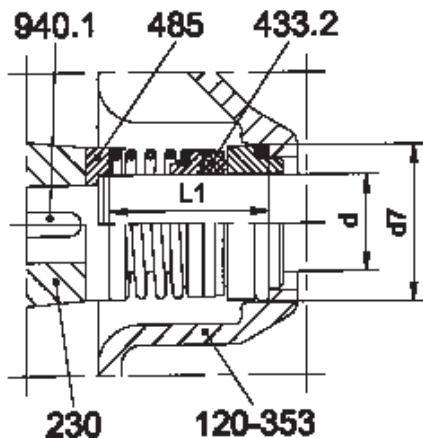

Figure 35

Typical mechanical seal drawing for
TRMB 25 – 32 and 40-110 & 150
TRVB 40-110 & 150

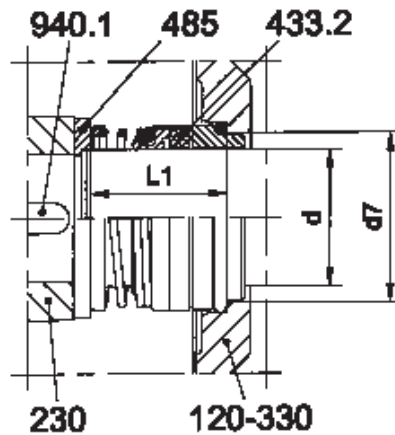

Figure 36

Typical mechanical seal drawing for
TRMB 40-200 & 50-300
TRVB 40-200 & 50-300

Place the electric motor VDMA 801 in the vertical position; attach the pump back cover to the motor flange with the screws VDMA 901 or 914.2.

The holes for locating pin VDMA 562 should be located at the lower part of the pump (toward the motor feet) for pump series "25 & 32" and at the upper part of the pump (away from the motor feet) for pump series "40 & 50".

Be sure that the seal stationary seat does not come out of its seat. Do not tighten the 4 bolts VDMA 901.

Check the impeller length against the depth of casing VDMA 101 in which the impeller must fit (see figure 37 for allowed tolerance). In the event the impeller is too long it will be required to machine it down.

A pre-assembly of spacer VDMA 485 and impeller VDMA 230 on the motor shaft is required.

Table 14
MECHANICAL SEAL DIMENSIONS (IN MM)

PUMP MODEL	d h6	D7 H8	L1 ±0.5
TRMB 25-30	22	37	37.5
TRMB 25-60	24	39	40
TRMB 32-50			
TRMB 32-75	28	43	42.5
TRMB & TRVB 40-110	35	50	
TRMB & TRVB 40-150			
TRMB & TRVB 40-200	45	63	45
TRMB & TRVB 50-300			

If needed, add shims between the spacer and the impeller so that the latter is 0.10 to 0.20 mm (depending upon the pump series) from the rear casing VDMA 120 (this will provide an even clearance on both sides of the impeller) see figure 38. Remove the impeller and the spacer with the shims, if previously added.

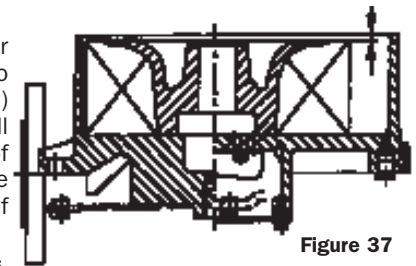

Figure 37

Proceed with the final pump assembly; lubricate the O-ring and shaft then insert on the shaft the rotating part of the mechanical seal VDMA 433.2. Be sure to keep both seal faces clean. Insert on the shaft the spacer VDMA 485 with shims (if needed). Push the spacer to compress the seal spring and insert the shaft key VDMA 940.1 in the keyway.

Insert the impeller and lock it on the shaft with the impeller nut(s) VDMA 920 or 922 or 923 or 923.1. Torque values are listed in figure 39.

Fit the 2 locating pins VDMA 562 in their respective seats.

Apply on the face of the pump casing VDMA 101, a coat of "Loctite 510" gasket material. Place the pump casing on the rear casing VDMA 120 using the locating pins for guide.

Insert the screws VDMA 914 with lock washers VDMA 554.5 and adjust torque to the values given in figure 39.

Place the pump in the horizontal position, using a level, check the flanges on the suction/discharge casing for horizontal accuracy.

Then torque the bolts VDMA 901 or VDMA 914.2 that attach the back cover to the electric motor.

Check the free rotation of the pump impeller by inserting a temporary screw on the motor shaft at the fan side.

To check the pump assembly and sealing it is required to test the pump hydrostatically.

Allow the pump gasket to cure for approximately two hours after assembly, apply then hydrostatic pressure to a max of 3 bar to see if there are any leaks.

Figure 38

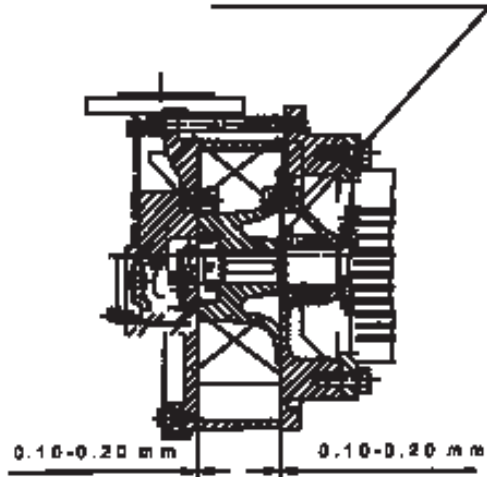

12.2 – ASSEMBLY OF PUMP SERIES "TRVB"

(See figure 35 or 36 and table 14 and 15 for mechanical seal and ball bearing dimensions).

Thoroughly clean every pump part with suitable tools and liquids compatible with the pump and elastomers materials.

The ball bearings should be washed with a degreaser (like naphtha), dry them and afterwards oil them.

To help with the assembly of the ball bearings on the shaft, they should be pre-heated to approximately 800C.

Place the shaft VDMA 210 in a vise, insert the ball bearing at drive end VDMA 320 and lock it in place with bearing nut VDMA 923, insert the V-ring VDMA 411.

Insert the elastic ring VDMA 935 in the bearing cover VDMA 360, slide the shaft with the ball bearing through the bearing cover. Insert the shoulder ring VDMA 505.2, apply pressure to the shaft to compress the elastic ring so that the circlip VDMA 932.2 can be placed in its seat.

If needed, install the shoulder ring VDMA 505.1 at the opposite side of the shaft (impeller side).

Table 15 - BALL BEARINGS, MODELS AND DIMENSIONS

PUMP MODEL	BALL BEARING MODEL	
	NON-DRIVE END	DRIVE END
TRVB 40-110	No 1 6208-2ZR	No 1 6208-2ZR
TRVB 40-150	(40x80x18)	(40x80x18)
TRVB 40-200	No 1 6210-2ZR	No 1 6208-2ZR
TRVB 50-300	(50x90x20)	(40x80x18)

Then place the ball bearing VDMA 320 or 320.1 over the shaft, introduce the circlip VDMA 932 and the thrower VDMA 507.

Introduce the shaft assembly in the bearing frame VDMA 330 or 353 and lock in place with screws VDMA 914.3.

Lubricate the stationary part of mechanical seal VDMA 433.2 with suitable liquid and insert this in the bearing frame (or in the back cover VDMA 120 previously located on the bearing frame, for pump construction "A3"), then lubricate the rotating part of the mechanical seal and slide it on the shaft.

Check the impeller length against the depth of casing VDMA 101 in which the impeller must fit (see figure 37 for allowed tolerance).

In the event the impeller is too long it will be required to machine it down.

Insert the impeller/mechanical seal spacer VDMA 485, place the shaft key VDMA 940.1 in the keyway, then the impeller VDMA 230 and lock with impeller nut VDMA 923 or 923.1.

Figure 39 – TORQUE VALUES FOR BOLTS AND NUTS OF VARIOUS DIAMETERS

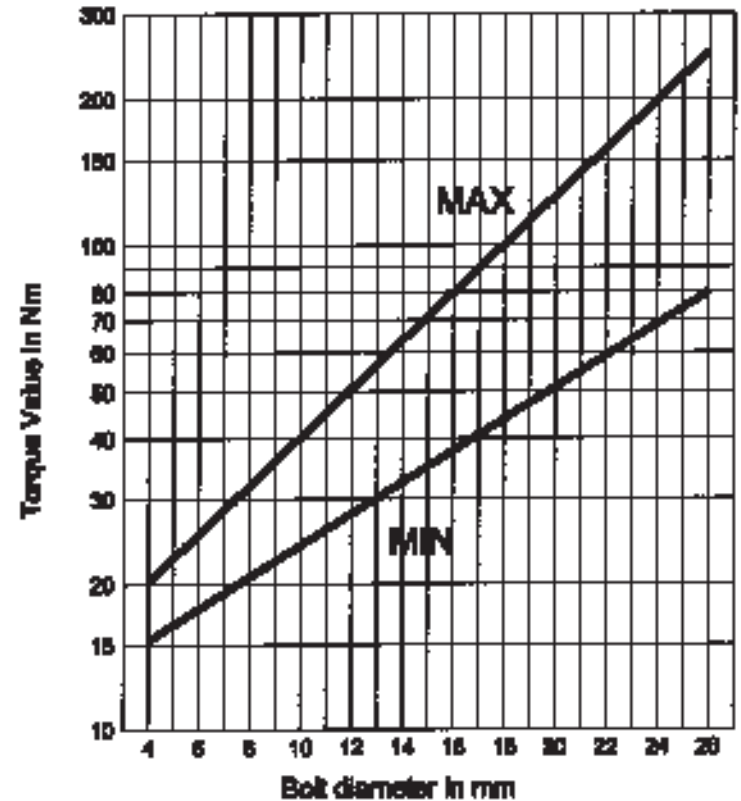

The clearance between the impeller and the suction/discharge casing VDMA 101 can be set from the outside, moving axially the bearing cover VDMA 360 with the grub screws VDMA 904.

Therefore adjust the impeller position by loosening the screws 914.3 and nut VDMA 920 and tightening the grub screws VDMA 904 until the back face of the impeller is 0.10-0.20 mm from the face of bearing frame (or from the back plate VDMA 120 for pumps in materials "A3").

At this time tighten the nut VDMA 920 and the screws VDMA 914.3. Apply on the face of the pump casing VDMA 101 a coat of "Loctite 510" gasket material.

Place the pump casing on the bearing frame using the locating pins VDMA 562 for guide, tighten the bolt VDMA 914 uniformly.

Check the free rotation of the pump rotor by hand to ascertain that there is no metal contact.

To check the pump assembly and sealing it is required to test the pump hydrostatically.

Allow the pump gasket to cure for approximately two hours after assembly, apply then hydrostatic pressure to a max of 3 bar to see if there are any leaks.

13 - RECOMMENDED SPARE PARTS

When ordering the pump, it is good practice to also order the necessary spare parts, especially when there are no stand-by pumps in the installation.

This will minimize unnecessary down times in the event of pump failures or routine maintenance.

It is therefore, recommended to stock the following spare parts for each pump size:

Pump series "TRMB"

- 1 Impeller
- 1 Mechanical seal
- 1 Electric motor
- 1 Gasket compound
- 1 Thread locking ring Elicel (for pump series "32")

Pump series "TRVB"

- 1 Impeller
- 1 Shaft assembly
- 2 Ball bearings
- 1 Mechanical seal
- 1 V-Ring
- 1 Gasket compound
- 1 Set of coupling inserts

For better parts management, the VDMA 24296 standards suggest to stock the number of parts as a function of the number of pumps being used in the plant.

On the pump nameplate are printed the pump model, year of manufacture and pump serial number. When ordering spare parts always refer to this information. Pump type, parts item number (VDMA) and description, as per the parts list on chapter 14 and pump sectional drawings on chapter 15, are useful information that helps to supply and ensure correct spare parts for your pump.

We recommend the use of original parts: in case of deviation, Travaini Pumps USA declines any responsibility for damages that may be derived from the use of non-original spare parts.

14 - PARTS LIST

VDMA NO	DESCRIPTION
101	Suction/discharge casing
554.3	Lock washer
110	Impeller casing
554.5	Lock washer
120	Rear casing
554.6	Lock washer
180.5	Valve plate
554.8	Lock washer
180.6	Metal cover
562...	Locating pin
183	Foot
672.S	Anti-cavitation valve
185	Motor flange
685	Guard
230	Impeller
801	Electric motor
320...	Ball bearing
861...	Half coupling
330	Bearing frame
892...	Raising pad
341	Motor lantern
900	Screw
353	Bearing frame
901...	Screw
360	Bearing cover
901.8	Bolt
400.9	Flapper
903...	Plug
411	V-Ring
904...	Grub screw
412	O-Ring
914...	Screw
421	Radial seal ring
920...	Nut
433.2	Mechanical seal
922	Impeller nut
485	Impeller and mechanical seal spacer
923...	Bearing nut
505...	Shoulder ring
932...	Circlip
507	Thrower
935	Elastic ring
554	Washer
940...	Key
554.1	Washer Z Liquid supply inlet

15 - TYPICAL SECTIONAL DRAWINGS

TRMB 25-30 & 25-60 (Motor frame: 80 & 90)

Applicable only for Stainless Steel "A3"

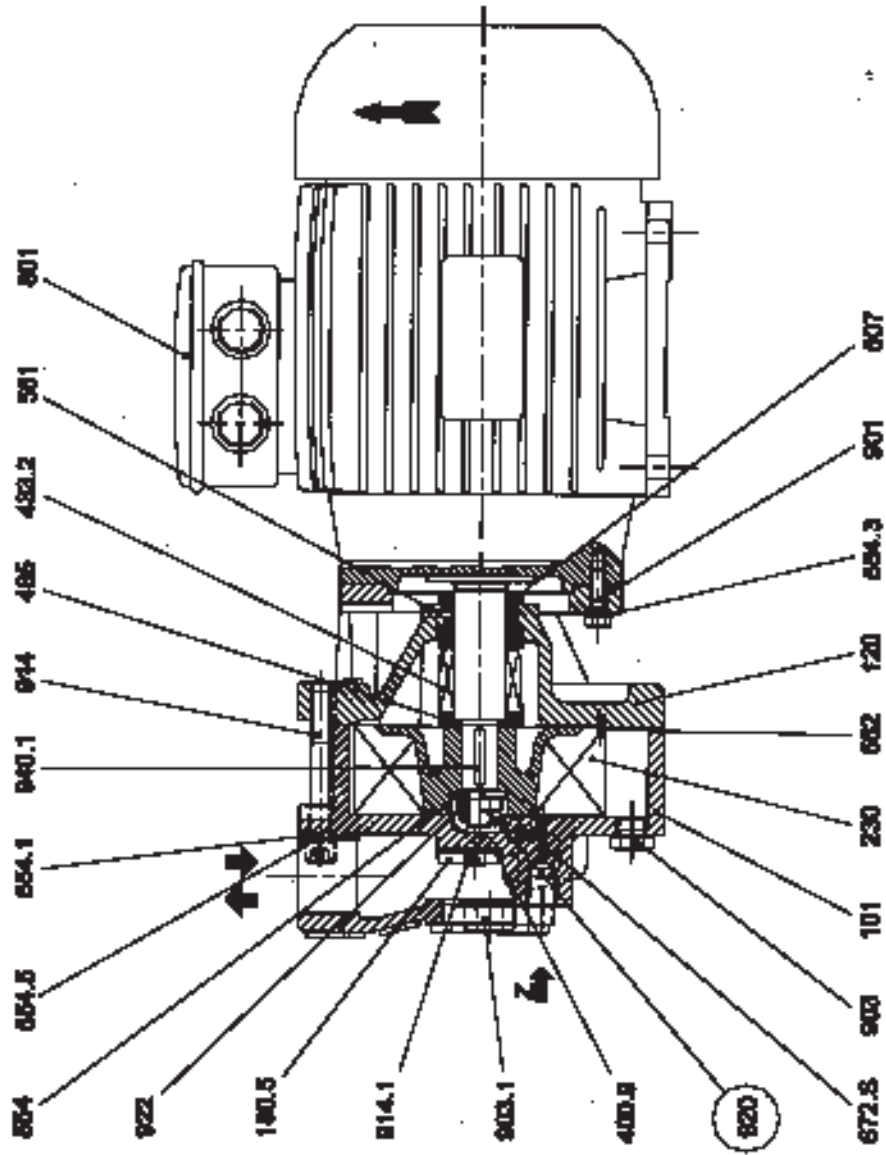

TRMB 32-50 & 32-75 (Motor frame: 90 & 100)

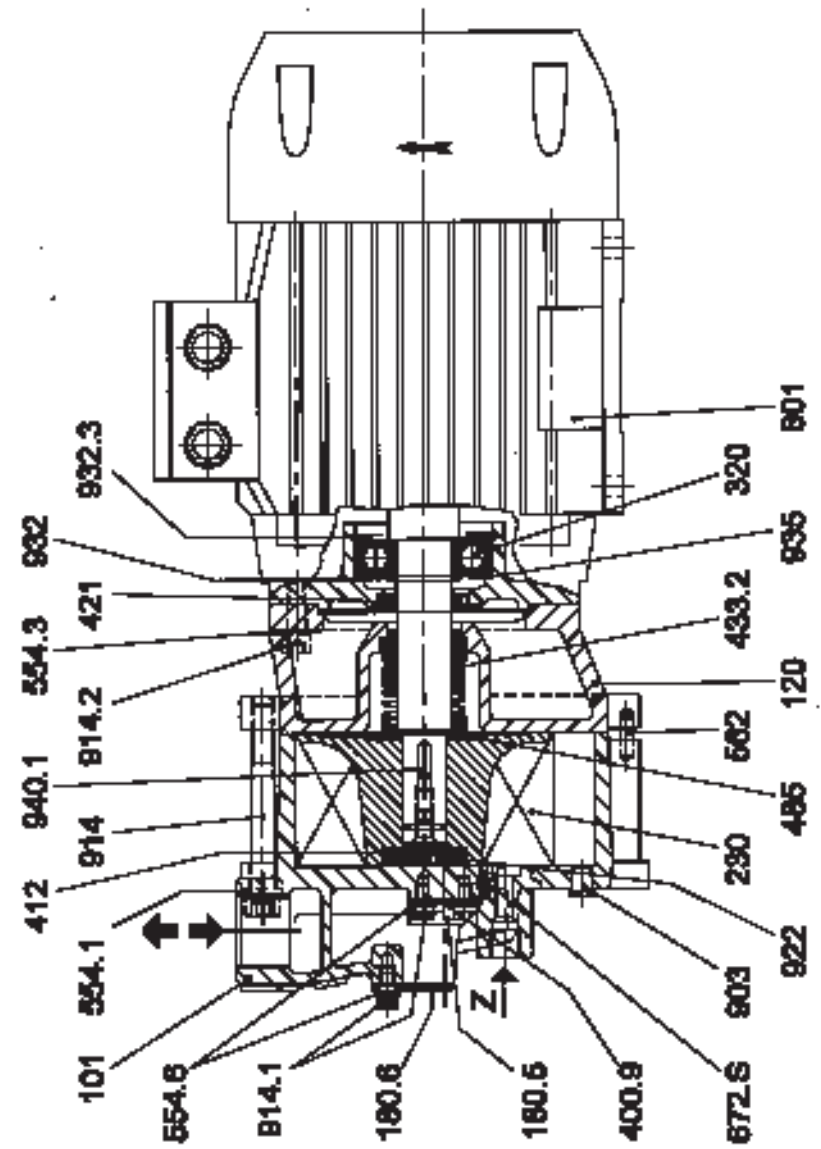

**TRVB 40-110 & 150 / C-M in materials "GH-F-RA"
(Motor frame: 110-112-132)**

Applicable only for material "RA"

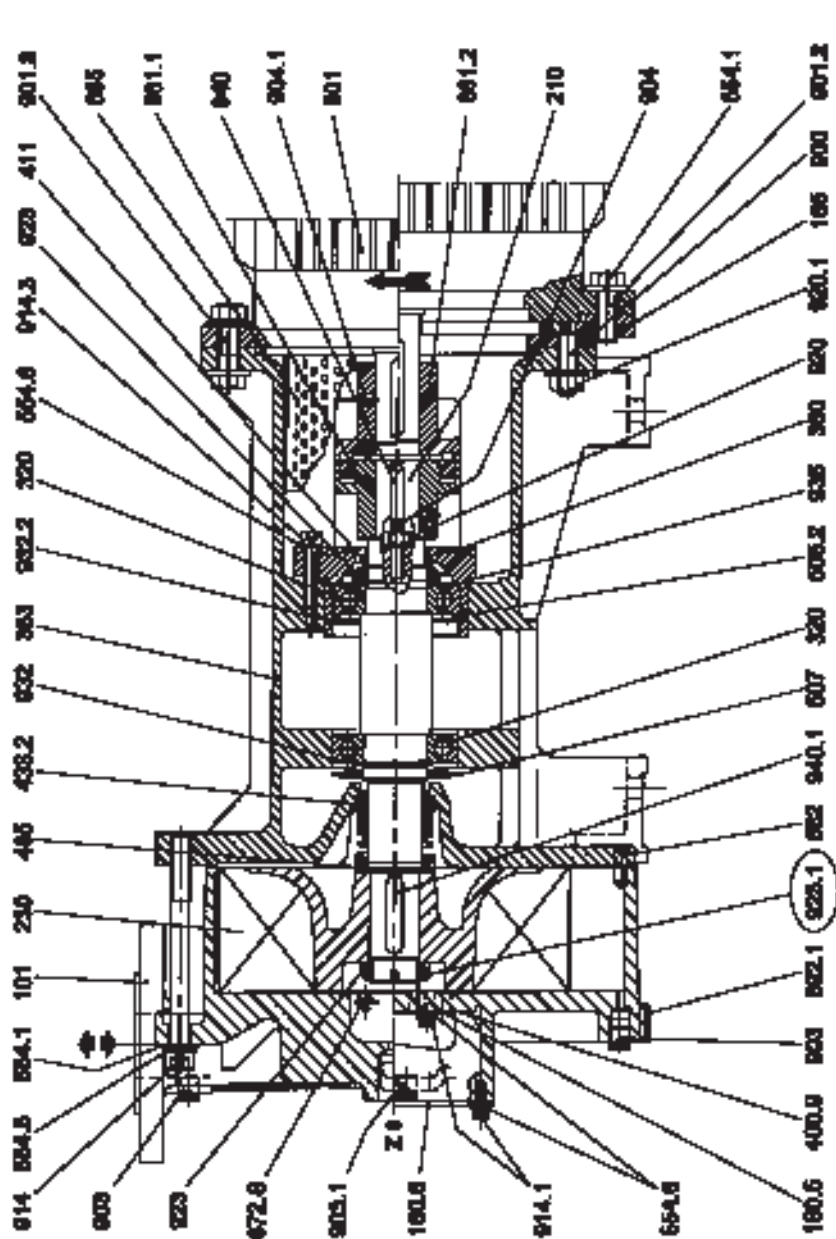

TRVB 40-110 & 150 / C-M in material "A3"

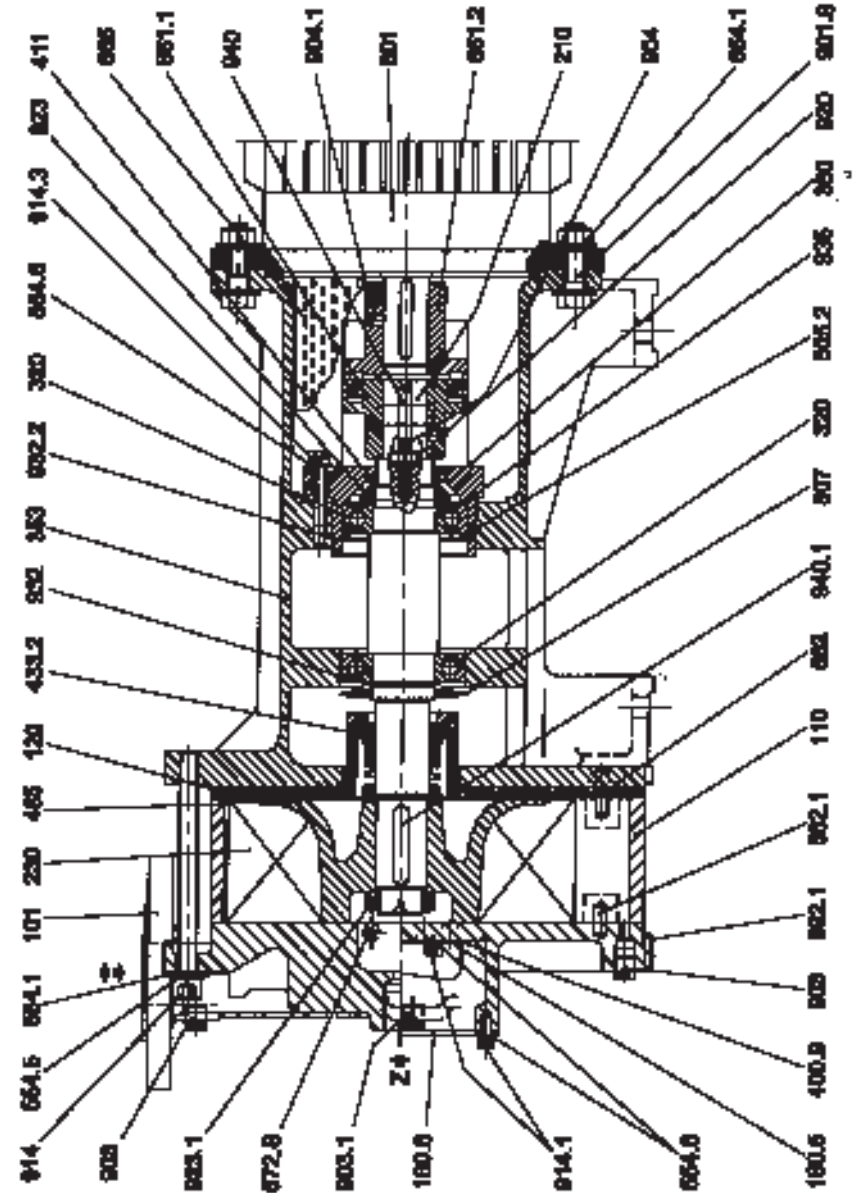



<h1>WARRANTY</h1>	<h1>TRAVAINI PUMPS USA</h1>
-------------------	-----------------------------

Subject to the terms and conditions hereof, Travaini Pumps U.S.A., Inc. (hereafter referred to as the "Company") warrants that the products and parts of its manufacture specified below, when shipped, and its services when performed, will be free from defects in material and workmanship for following warranty time periods:

PRODUCT DESCRIPTION	WARRANTY PERIOD FROM DATE OF SHIPMENT
Liquid Ring Vacuum Pump system or pump products	Two (2) years
Rotary vane system or pump products	24 / 18 months if TPUSA oil used / not used
Centrifugal pump products	18 months, or 12 months from date of installation, whichever occurs first
Mechanical seals	3 months
Repaired pumps / systems	6 months for the repair / work performed

This Warranty shall apply to liquid ring vacuum products only if they are operated with Company approved seal fluids and to rotary vane products only if they are operated with Company approved lubricants. In-warranty repaired or replaced products are warranted only for the remaining unexpired portion of the warranty period applicable to the repaired or replaced product(s).

This Warranty does not extend to equipment such as electric motors, starters, heat exchangers and other accessories furnished to the Company by third party manufacturers and/or suppliers. Said accessories are warranted only to the extent of any warranty extended to the Company by such third party manufacturers and/or suppliers. Replacement of maintenance items, including, in particular, seals, bearings, filters, etc. supplied in connection with standard maintenance service provided by the Company are not covered by this Warranty. Any technical assistance, advice, or comments provided by the Company regarding system components, other than those manufactured by the Company, are not covered under this Warranty; the Company disclaims any liability in connection with same. The Company disclaims any liability in connection with the malfunctioning of any system(s) or component(s) of system(s) which conform to designs, specifications and/or instructions mandated by purchasers.

This Warranty is limited exclusively to products and/or parts of the Company properly installed, serviced and maintained in full compliance with the Operating and Maintenance manual of the Company. This Warranty shall not extend to products and/or parts which

have been misused or neglected or not used for the purpose(s) for which they were intended, including, in particular, products operated at/in excessive temperature or dirty environments, products used in conjunction with corrosive, erosive or explosive liquids or gasses, and/or products malfunctioning as a result of build-up of material in the internal parts thereof. Products which are disassembled without the prior written consent of the Company and/or which are repaired, modified, altered or otherwise tampered with in any manner inconsistent with the Operating and Maintenance manual of the Company are not covered under this Warranty. Products and/or parts which are kept in "long term" storage, as such terms are defined in the Operations & Maintenance manual of the Company, and not maintained in accordance with Company long term care procedures specified by the Company are not covered under this Warranty.

Warranty claims must be made within the warranty period specified above for each of the Company's products and services and include the serial number thereof. The Company's obligations under this Warranty are limited, in the Company's sole discretion, to repair, replacement or refund of the purchase price received by the Company for the product, part or service. Notwithstanding the foregoing, the Company shall have the option to provide alternative solutions of a different design. In no event shall the purchaser and/or any subsequent owner or beneficiary of the products, parts and/or services be entitled to recover incidental, special or consequential damages arising out of the breach of this Warranty or any defect, failure or malfunction of the products and/or services supplied by the Company.

A written return authorization must be obtained from the Company prior to the return of any product and/or part under this Warranty. Products and parts are to be returned only to the Company's facilities or such facilities as the Company may designate in writing. Costs of uninstalling/ reinstalling the product and/or any part under Warranty, as well as all costs associated with the shipment thereof to and from the facilities of the Company shall be at the owner's sole expense.

THIS WARRANTY AND THE COMPANY'S OBLIGATIONS HEREUNDER ARE EXPRESSLY IN LIEU OF ALL OTHER WARRANTIES, INCLUDING BUT NOT LIMITED TO IMPLIED WARRANTIES OF MERCHANTABILITY AND FITNESS FOR A PARTICULAR PURPOSE. ALL WARRANTIES WHICH EXCEED THE AFOREMENTIONED OBLIGATIONS ARE HEREBY DISCLAIMED BY THE COMPANY AND EXCLUDED FROM THIS WARRANTY, WHETHER BASED ON CONTRACT, WARRANTY, NEGLIGENCE, INDEMNITY, STRICT LIABILITY OR OTHERWISE. NO EMPLOYEE OF THE COMPANY OR OTHER PERSON IS AUTHORIZED TO GIVE ANY OTHER WARRANTY OR TO ASSUME ANY OTHER LIABILITY ON THE COMPANY'S BEHALF.

Effective as of January 2007