

TRAVAINI PUMPS USA

TRHE 32-4

Two Stage High Vacuum Pumps

PERFORMANCE DATA	: From 60 Torr	CAPACITY:	2 - 4 cfm
FEATURES	: Two-stage rotating pump with external grease lubricated bearings.		
SHAFT SEALING	: Mechanical seal - Double mechanical seal.		
OPTIONS	: Bareshaft pump - Coupled motor on baseplate – Monoblock with electric motor		



TECHNICAL DATA			
PUMP TYPE		TRHE 32-4	
Speed	RPM	1450	1750
Motor - installed power	HP	0.7	1
Average service liquid flow	GPM	0.75	0.75
Noise level at 75 Torr	dB(A)	67	68
Minimum suction pressure	Torr	60	60

Pumps provided with threaded connections for service liquid, pump draining, anticavitation valve and companion flanges. Pumps are also provided, by request, with flanged air-liquid separator tank, non return valve, ejector, vacuum relief valve, valve to control the flow of the liquid supply, vacuum gauges, pressure gauges and compound gauges. We can also provide information on our water sealed and oil sealed systems. For more detailed information please contact our Sales Office.

Example for Model Designation	
<u>T R H E 32 - 4 / C - M / GH</u>	
R	Travaini Pump USA construction
R	Liquid Ring Pump
H	Two stage pump for high vacuum
E	Design number
32	Flange size (mm)
4	Nominal capacity (m ³ /h)
C	Shaft sealing C = Mechanical seal C2 = Double mechanical seal
M	Closed-coupled construction with lantern (by request)
GH	Materials of construction GH-F-RA-A3 = See table

Standard Materials of Construction					
PART No.	Description	GH	F	RA	A3
106	Suction casing	Cast Iron			
107	Discharge casing				
140	Port plate				
210	Shaft	Stainless Steel AISI 420		Stainless Steel AISI 316	
357	Bearing housing mech. seal	Cast Iron			
230	Impeller	Bronze	Ductile Iron	Stainless Steel AISI 316	

Special Materials Available Upon Request

Indicative table: for further information please consult our Sales Office

DATA BASED ON :
 DRY AIR AT 68 °F - 20 °C
 SATURATED AIR AT 68 °F - 20 °C
 SERVICE LIQUID WATER
 SERVICE LIQUID TEMPERATURE 59 °F - 15 °C
 DISCHARGE PRESSURE 1013 mbar

S.S. PUMPS
 CAPACITY: -10%

Tol.: 10%

PERFORMANCE DATA
 LIQUID RING VACUUM PUMP
 PUMP MODEL

TRHE 32-4

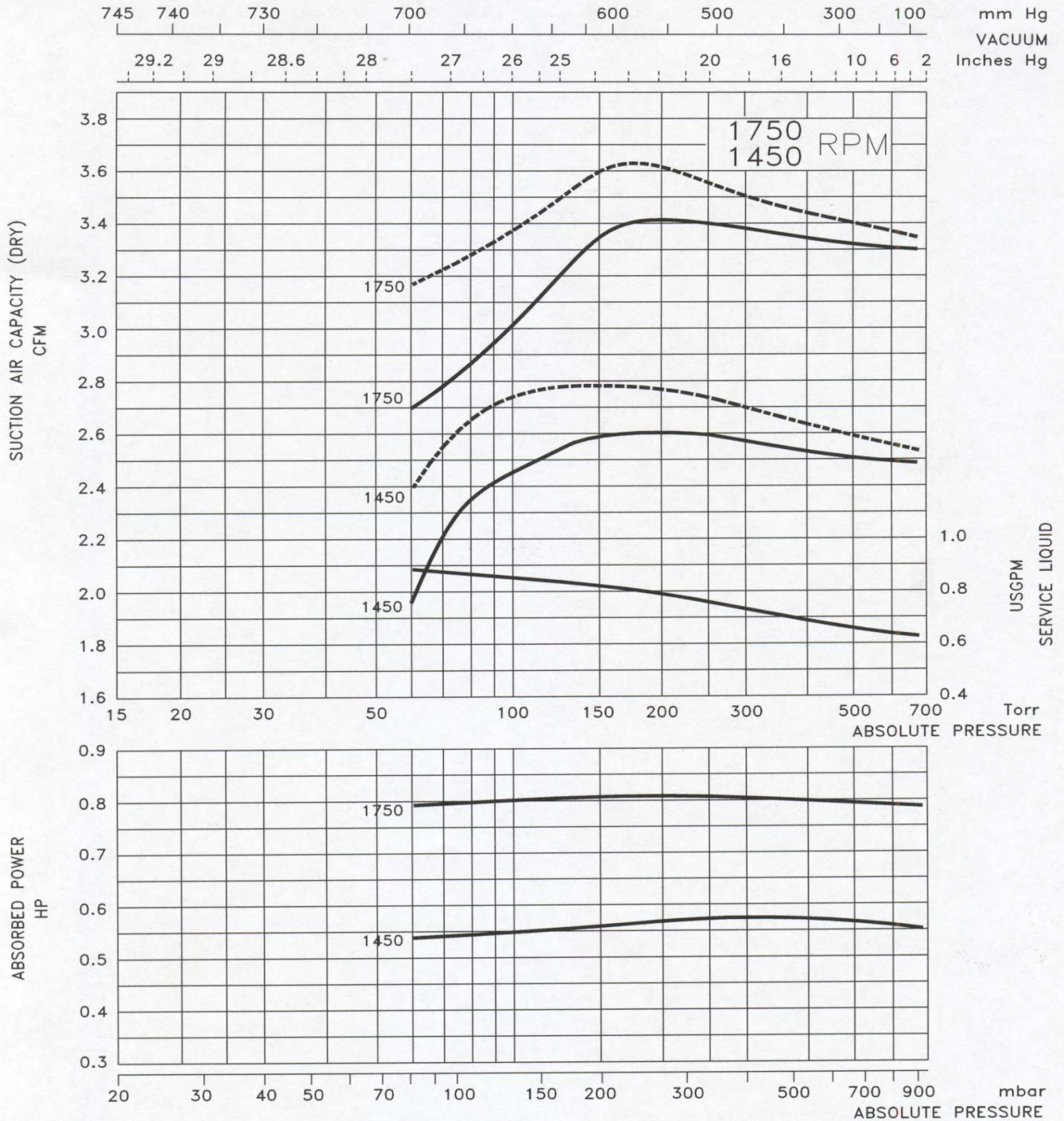

DATE: APRIL 97

PAGE NO: 4-110

TRHE 32-4/C

Bareshaft Construction with Mechanical Seal

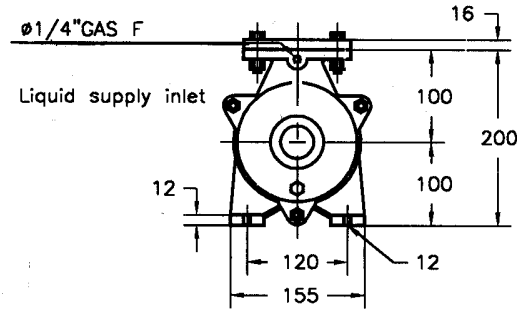
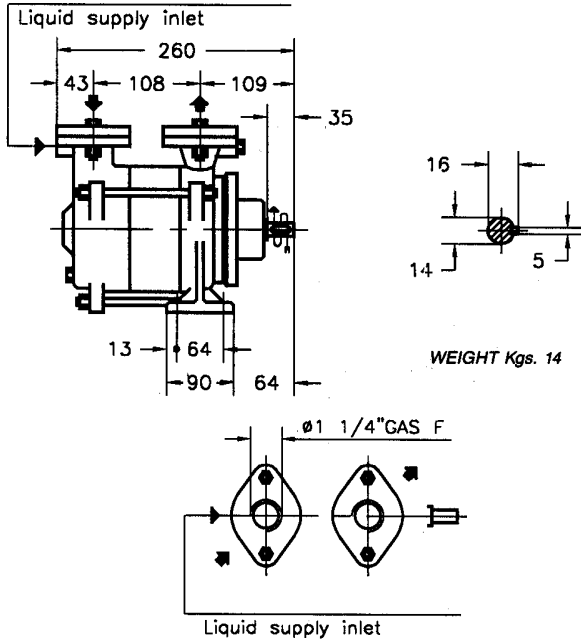

Note: Dimensions in mm.
(mm to in = /25.4)

Closed-Coupled Construction with Mechanical Seal

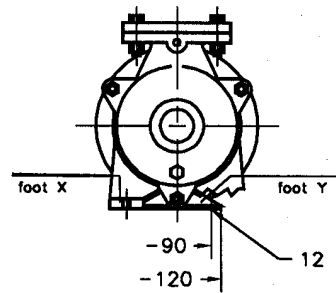
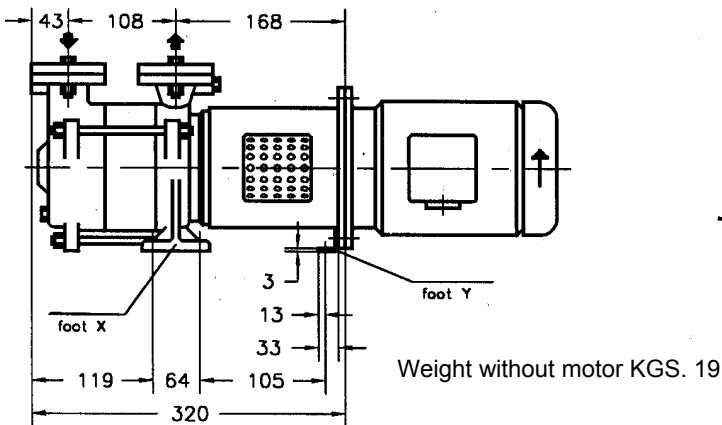

Base-Mounted Construction (Baseplate-Coupling) with Mechanical Seal

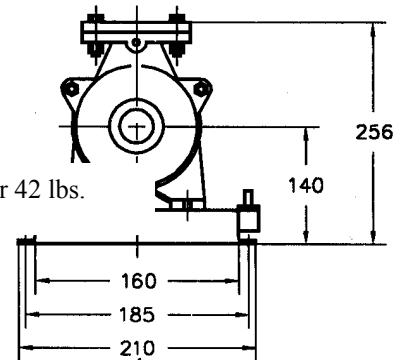
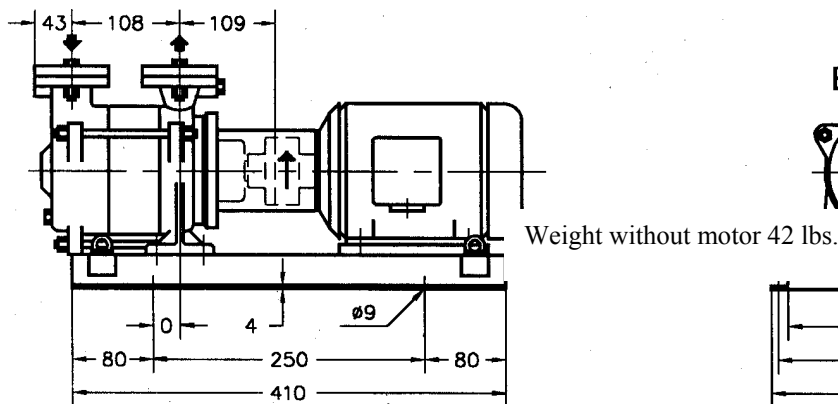

The weights refer to the GH construction
Dimensions are only for reference. Please consult the factory for certified drawings.

TRHE 32-4/C

Typical Cross Section with Mechanical Seal

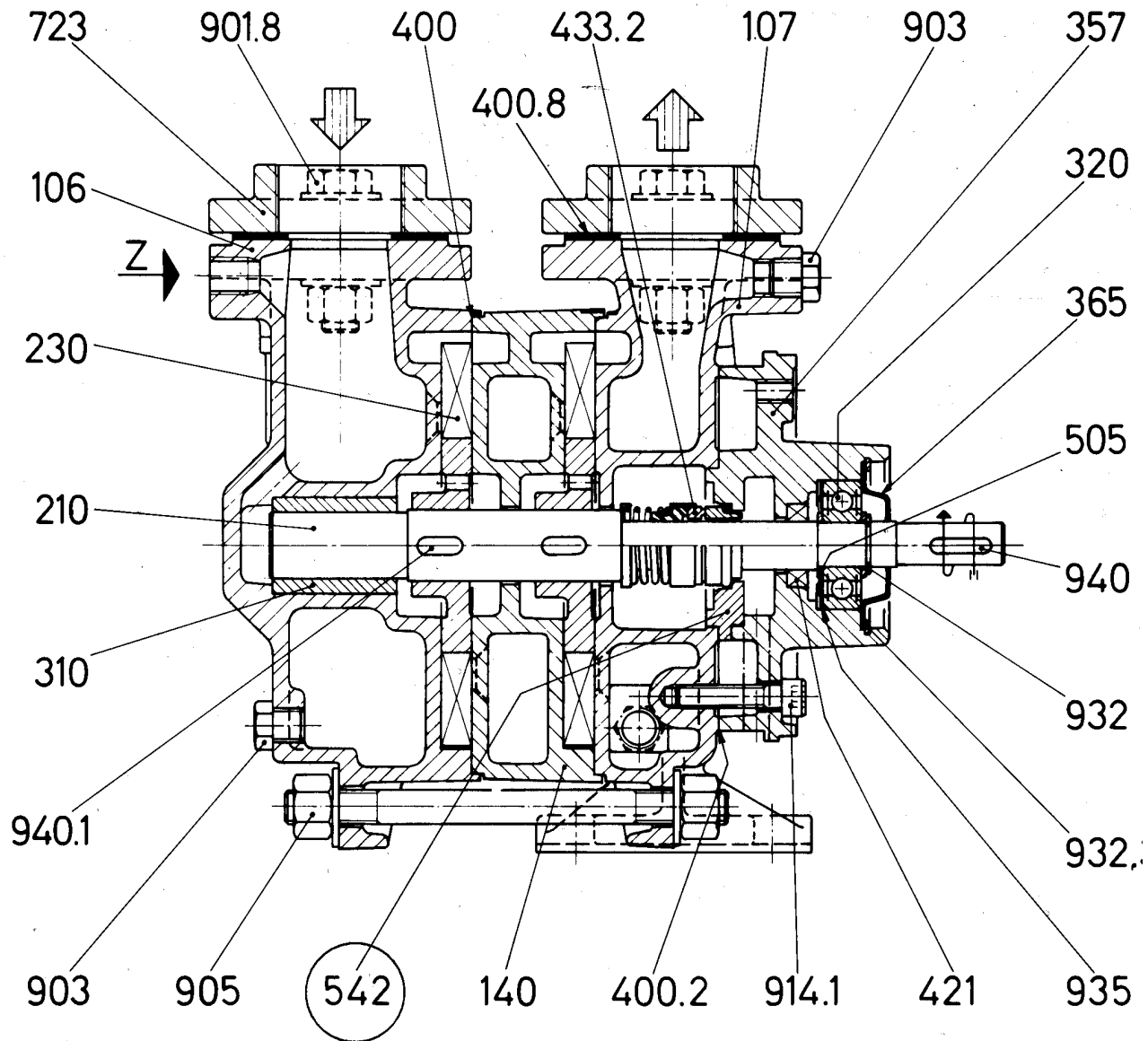

Components

Part No.	Designation	Part No.	Designation	Part No.	Designation
106	Suction casing	• 400	Gasket	903	Plug
107	Discharge casing	• 400.2	Gasket	905	Tie-bolt
140	Intermediate element	• 400.8	Gasket	914.1	Screw
• 210	Shaft	• 421	Radial seal ring	932	Circlip
• 230	Impeller	• 433.2	Mechanical seal c.w.	932.3	Circlip
310	Bearing bush	• 505	Shoulder ring	935	Elastic ring
• 320	Ball bearing	542	Seal bush		Key
357	Bearing and mech. seal housing		(A3 construction only)	.1	Key
365	Bearing cover	723	Companion flange		Liquid supply inlet
		901.8	Bolt		

○ = A3 construction only

• = Recommended spare parts