

Serie PVL

Pompa per vuoto lubrificate a palette
Lubricated vane vacuum pump

PVL401 - PVL401/B PVL541 - PVL541/B

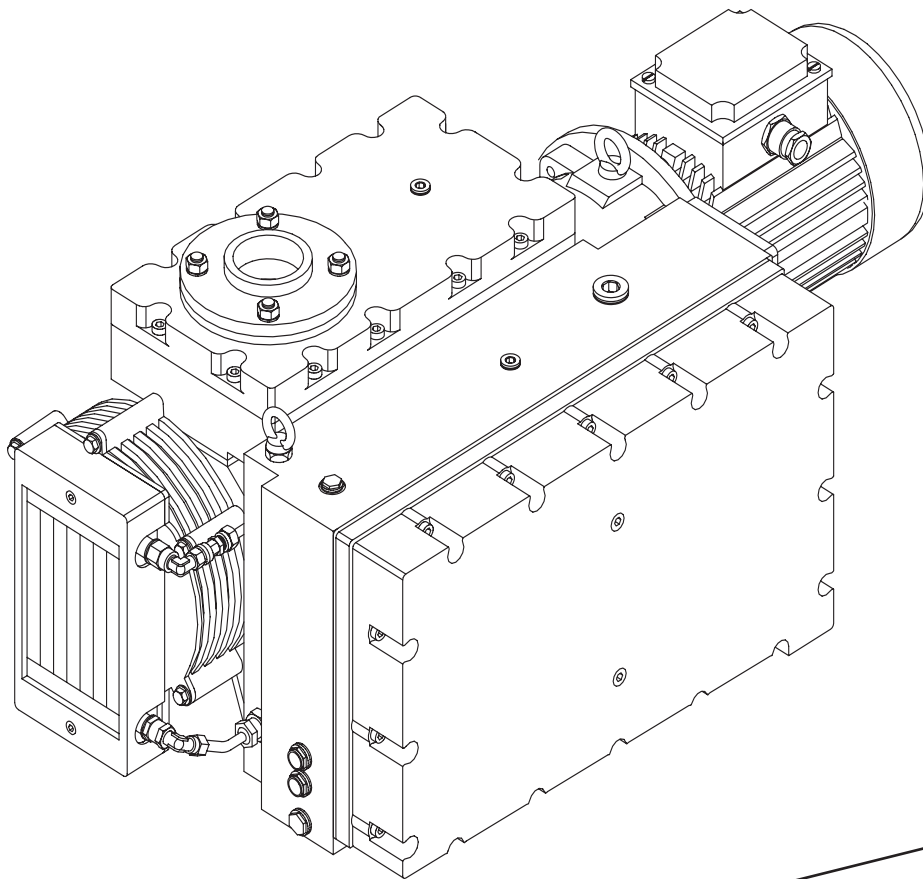

NOTICE: This document contains references to P.V.R. Please note that P.V.R. s.r.l. is now part of Agilent Technologies. For more information, go to www.agilent.com/chem/vacuum.

Agilent Technologies
Agilent Technologies Italia S.p.A. Vacuum Products Division
Via Santa Vecchia, 107 - 23868 Valmadrera (LC) ITALY

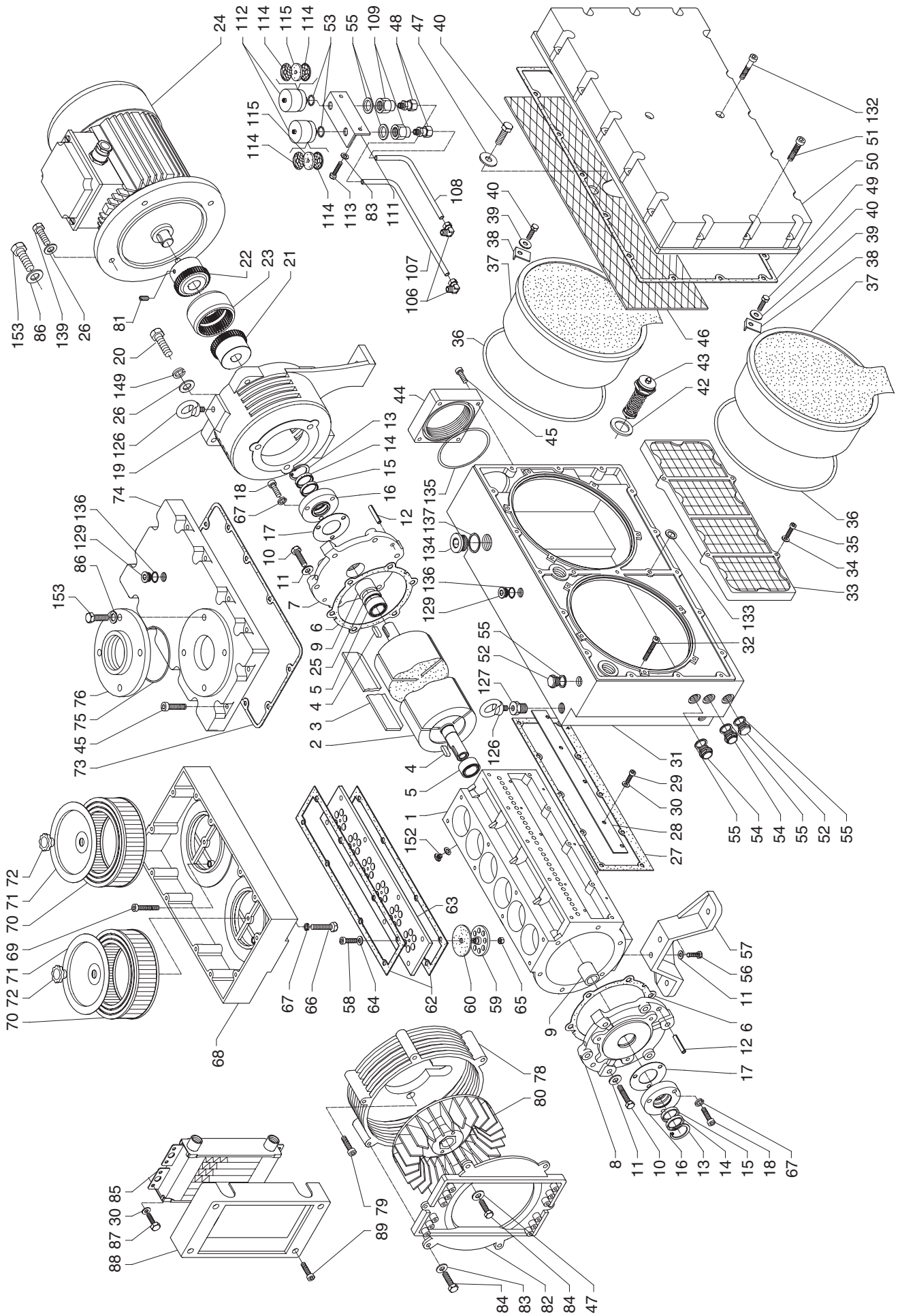

POS.	DENOMINAZIONE	DESCRIPTION	Q.TA'		POS.	DENOMINAZIONE	DESCRIPTION	Q.TA'		
			PVL	PVL/B				PVL	PVL/B	
1	Statore	Body of pump	1		74	Coperchio vaschetta aspirazione	Suction tank cover	1		
2	Rotore	Rotor	1		75	O.R. 4450	O Ring n. 4450	1		
3	Paletta	Vane	6		76	Flangia 3" G	3" G Suction flange	1		
4	Chiavetta 10x35	10x35 Key	2		78	Copriventola	Fan cover	1		
5	Cuscinetto rulli Nu307	Nu307 Roller bearing	2		79	Vite T.C.E.I. M12x20	M12x20 Hex. socket head screw	3		
6	Guarnizione carta	Paper gasket	2		80	Ventola	Fan	1		
7	Coperchio lato motore	Motor side cover	1		81	Grano M8x12	Grano M8x12	1		
8	Coperchio lato ventola	Fan side cover	1		82	Supporto radiatore	Oil cooler support	1		
9	Anello interno JR 35x40x30	JR 35x40x30 Inner ring	2		83	Rosetta Ø8	Ø8 Washer	8		
10	Vite T.E.I.F. M10x45	M10x45 Hex. screw	12		84	Vite T.E.I.F. M8x20	M8x20 Hex. screw	7		
11	Rosetta Ø10	Ø10 Washer	14		85	Radiatore	Oil cooler	1		
12	Spina Ø6x24	Ø6x24 Pin	4		86	Rosetta Ø14	Ø14 Washer	4		
13	Anello seeger J56	Ø56 Retaining ring for bores	2		87	Vite T.E.I.F. M6x20	M6x20 Hex. screw	4		
14	Anello tenuta FKM 40-55-7	40-55-7 Viton seal ring	2		88	Copiradiatore	Oil cooler cover	1		
15	Anello tenuta FKM 40-52-7	40-52-7 Viton seal ring	2		89	Vite T.C.E.I. M6x50 (M6x90)	(M6x90) M6x50 Hex. socket head screw	4		
16	Coperchietto anelli tenuta	Seal ring cover	2		90	Rosetta AI Ø27x21 Sp.2	Ø27x21 th. 2 Aluminium washer	2(0)		
17	Guarnizione coperchio anelli di tenuta	Seal ring cover gasket	2		91	Nippio filetto 1/2" G 1.35	1/2" G Nipple	2(0)		
18	Vite T.C.E.I. M8x20	M8x20 Hex. socket head screw	6		92	Raccordo a L M.M. 3/8"-3/8"	3/8"-3/8" Union elbow	1		
19	Manicotto x motore	Sleeve	1		93	Raccordo diritto M. 3/8" 12/10	3/8" No - return valve	2		
20	Vite T.E.I.F. M12x60	M12x60 Hex. screw	3		94	Tubo uscita radiatore	3/8" Straight union	1		
21	Semigiunto pompa	Pump Coupling half	1		95	Raccordo a T F.F.F. 3/8"	Pipe (outlet oil cooler)	1		
22	Motor	Motor Coupling half	1		96	Raccordo a T F.F.F. 3/8"	3/8" Pipe fitting	1		
23	Manicotto per giunto	Coupling sleeve	1		97	Raccordo diritto M. 3/8" 10/8	3/8" Straight union	3		
24	Motor elettrico	Electric motor	1		98	Tubo olio lato ventola	Pipe (fan side)	1		
25	Distanziale Ø35/45x3	Ø35/45x3 Spacer	1		99	Raccordo a L M. 1/4" 10/8	1/4" Union elbow	2		
26	Rosetta Ø12	Ø12 Washer	7(3)		100	Prolunga M.F. W 1/4" corta	1/4" Extension	2		
27	Guarnizione pompa-serbatoio	Pump - tank gasket	1		101	Raccordo F.F. 1/2"	Pipe (Motor side)	1		
28	Deflettore	Plate	1		102	Raccordo a L M. 1/2" 16/14	1/2" Pipe fitting	1(0)		
29	Vite T.C.E.I. M6x16	M6x16 Hex. socket head screw	5		103	Tubo ingresso radiatore	1/2" Union elbow	1		
30	Rosetta Ø6	Ø6 Washer	9		104	Raccordo diritto M. 1/2" 16/14	Pipe (inlet oil cooler)	1		
31	Serbatoio	Tank	1		105	Raccordo diritto M. 1/2" 16/14	1/2" Straight union	1		
32	Vite T.C.E.I. M8x60	M8x60 Hex. socket head screw	10		106	Raccordo a L M. 1/4" 8/6	1/4" Union elbow	2		
33	Telaio diffusore	Diffuser	1		107	Tubo lungo per zavorratore	Long pipe for gas ballast valve	1		
34	Rosetta Ø6x24	Ø6x24 Washer	4		108	Tubo corto x zavorratore	Short pipe for gas ballast valve	1		
35	Vite T.C.E.I. M6x40	M6x40 Hex. socket head screw	4		109	Prolunga F.F. 3/8" 1/2"	3/8"-1/2" Extension	3(2)		
36	O.R. Ø1293 Sp.4	O Ring Ø293 th.4	2		110	Squadretta porta zavorratori	Angle	2		
37	Separatore olio	Oil separator	2		111	Zavorratore 1/2" G	1/2" G Gas ballast valve	2		
38	Squadretta separatore	Angle	10		112	Vite T.E.I.F. M8x16	M8x16 Hex. screw	2		
39	Rosetta 9x27	Ø9x27 Washer	10		113	Lamiera microstrata zavorratore	Gas ballast valve micro - stretched sheet	4		
40	Vite T.E.I.F. M8x25	M8x25 Hex. screw	11		114	Disco feltro Ø42/8x4	Ø42/8x4 Felt disk	2		
42	Rosetta fibra Ø 1" G	1" G Fiber washer	2		115	Raccordo diritto M. 1/8" 6/4	1/8" Straight union	5		
43	Valvola sicurezza 1" G	1" Safety valve	2		116	Tubo sfogo lato motore	Pipe (outlet motor side)	1		
44	Flangia 3"	3" G Flange	1		117	Tubo sfogo lato ventola	Pipe (outlet fan side)	1		
45	Vite T.C.E.I. M8x30	M8x30 Hex. socket head screw	16		118	Tubo recupero olio	Oil recovery pipe	1		
46	Lamiera microstrata separatore	Micro - stretched sheet	1		119	Valvola ritengo 1/8"	1/8" No - return valve	0		
47	Rosetta 8x40	Ø8x40 Washer	2		120	Raccordo a L M.M. 1/8"-1/8"	1/8" Union elbow	1		
48	Raccordo diritto 3/8" 8/6	3/8" Straight union	2		121	Raccordo nipplo 3/8"-1/4"	3/8"-1/4" Nipple	1		
49	Guarnizione coperchio serbatoio	Tank cover gasket	1		122	Gomito M.F. ghisa 1/4"	1/4" G Union elbow	1		
50	Coperchio serbatoio	Tank cover	1		123	Tubo olio supplementare	Pipe (oil recovery)	1		
51	Vite T.C.E.I. M8x40	M8x40 Hex. socket head screw	16		124	Raccordo a L M. 3/8" 10/8	3/8" Union elbow	2		
52	Tappo 1/2" G	1/2" G Plug	2		125	Goifaro M16	M16 Eyebolt	2		
53	O.R. 3075	O Ring n. 3075	2		126	Tappo per goifaro M16	Ø2.5 adapter (oil recovery)	1		
54	Spia olio 1/2" G	1/2" G Oil sight glass	2		127	Raccordo diritto M. 1/8" 6/4	1/8" Plug	2		
55	Rosetta fibra Ø 1/2" G	1/2" G Fiber washer	6		128	Raccordo a L M. 3/8" 12/10	3/8" Union elbow	1		
56	Vite T.E.I.F. M10x30	M10x30 Hex. screw	2		129	Tappo 3/8"	3/8" Plug	2		
57	Piedino	Foot	1		130	Guarnizione Ø26/10 Sp.1	Ø26/10 th.1 Washer	2		
58	Vite T.E.I.F. M6x35	M6x35 Hex. screw	6		131	Vite T.C.E.I. M8x85	M8x85 Hex. socket head screw	2		
59	Disco supporto valvola	Support valve disk	6		132	Tappo 1"	1" Plug	1		
60	Gomma Ø62/10x3	Ø62/10x3 Rubber disk	6		133	G	Guarnizione Ø26/10 Sp.1	Ø26/10 th.1 Washer	2	
62	Guarnizione piastra aspirazione	Suction plate gasket	2		134	G	O.R. 4362	O Ring n.4362	1	
63	Piastra aspirazione	Suction plate	1		135	G	Rosetta AI per tappo 1" G	1" G Aluminium washer	1	
64	Rosetta AI Ø6	Ø6 AI washer	6		136	Rosetta AI per tappo 3/8" G	3/8" G Aluminium washer	2		
65	Dado autobloccante M6	M6 Locknut	6		137	Rosetta AI per tappo 1" G	1" G Aluminium washer	2		
66	Vite T.E.I.F. M8x35	M8x35 Hex. screw	2		138	Vite T.E.I.F. M12x40	M12x40 Hex. screw	1		
67	Rosetta elastica Ø8	Ø8 Lock washer	8		139	Raccordo a L M. 1/8" 6/4	1/8" Union elbow	0		
68	Vaschetta aspirazione	Suction tank	1		140	Tubo recupero olio x PVL/B	PVL/B Oil recovery pipe	0		
69	Vite T.C.E.I. M8x50	M8x50 Hex. socket head screw	8		141	Tappo con bicono Ø6	Ø6 Biconic plug	0		
70	Cartuccia aspirazione	Filter cartridge	2		142	Prolunga M/F 1/8"-1/8"	1/8"-1/8" Pipe fitting	0		
71	Parabola premifiltro	Parabola premifilter	2		143	Rosetta elastica Ø12	Ø12 Elastic washer	3		
72	Volantino F. M8x40	M8x40 Female knob	2		144	Riduzione M/F 3/4"-3/8"	3/4"-3/8" M/F adapter	0		
73	Guarnizione coperchio vaschetta aspirazione	Suction cover gasket	1		145	Riduzione M/F 3/4"-1/2"	3/4"-1/2" M/F adapter	0		
					146	Tappo + rosetta 1/8" G	1/8" G Plug + washer	1		
					147	Vite T.E.I.F. M14x40	M14x40 Hex. Screw	4		
					148					
					149					
					150					
					151					
					152					
					153					

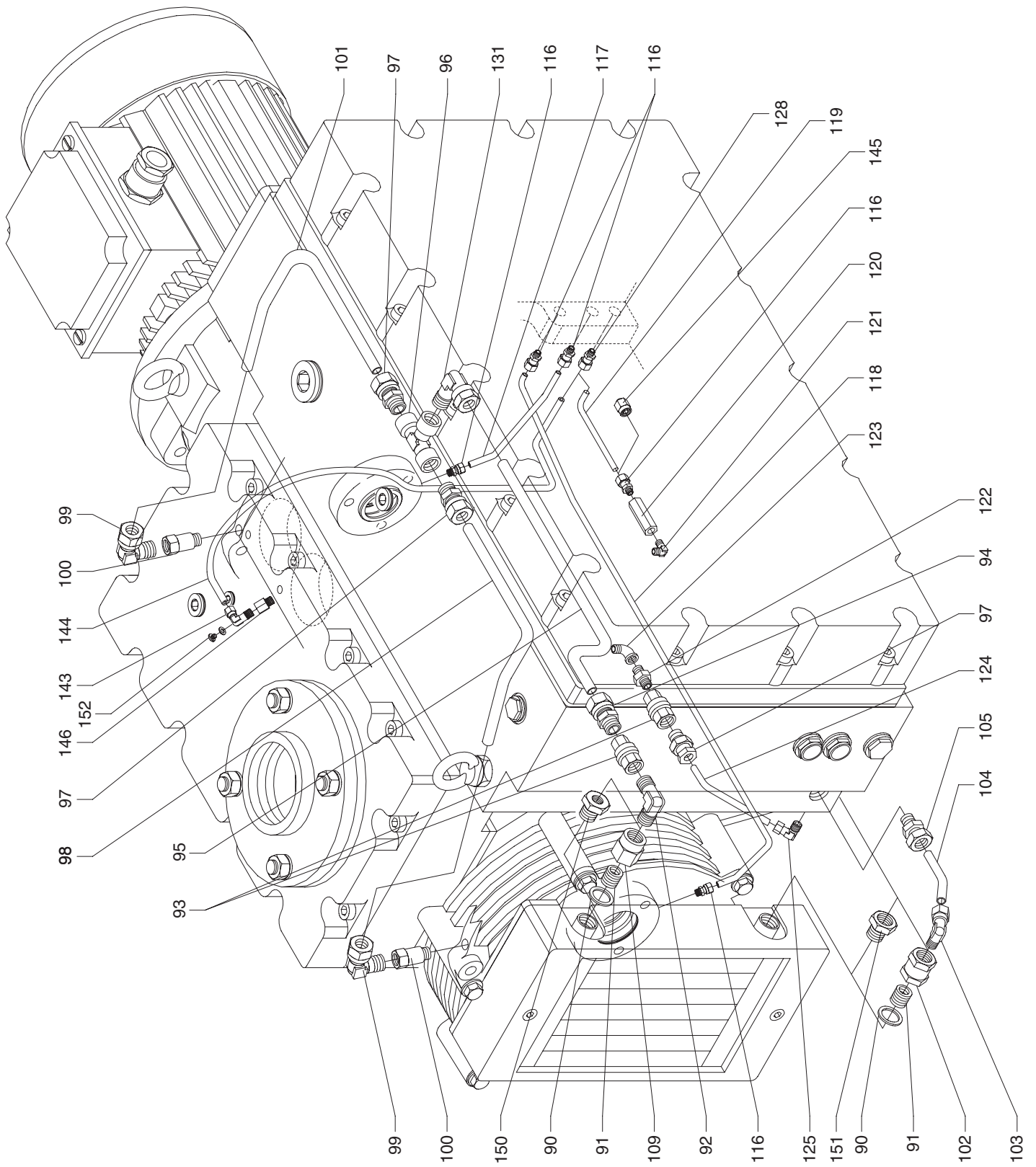

NOTICE: This document contains references to P.V.R. Please note that P.V.R. s.r.l. is now part of Agilent Technologies. For more information, go to www.agilent.com/chem/vacuum.

 **Agilent Technologies**

Agilent Technologies Italia S.p.A. Vacuum Products Division
Via Santa Vecchia, 107 - 23868 Valmadrera (LC) ITALY



La **P.V.R.** declina ogni responsabilità per uso improprio o non conforme alle istruzioni fornite, manomissione e manutenzione inadeguata della pompa.

P.V.R. declines any responsibility for improper use of the instructions, mishandling or pump unsuitable servicing.



P.V.R. s.r.l. - Via Santa Vecchia, 14 - 23868 Valmadrera (LC) Italy
Tel. +39 0341 581 801 - Telefax +39 0341 580 335
E-mail: pvr@pvr.it - www.pvr.it