

BOOSTER VUOTO 73-103 HV
Vacuum Booster 73-103 HV

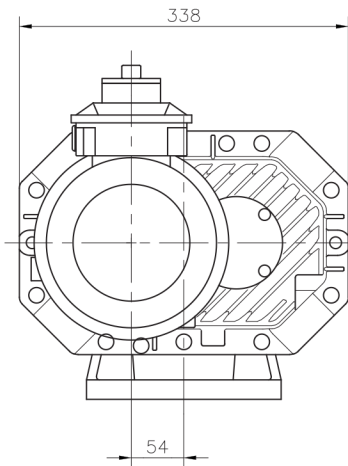

Drive end view / Vista lato comando

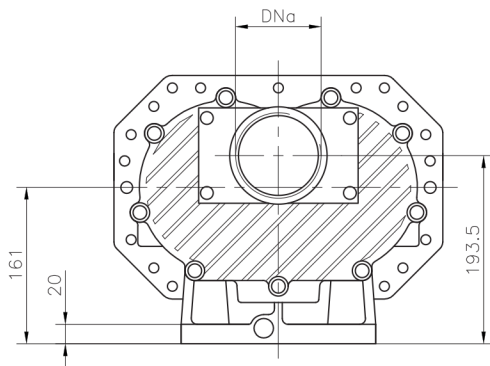
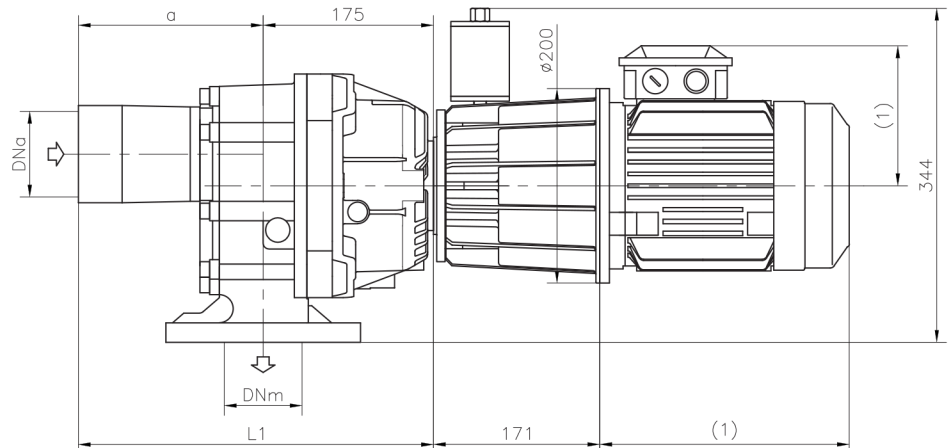

Non-drive end view / Vista lato opposto comando

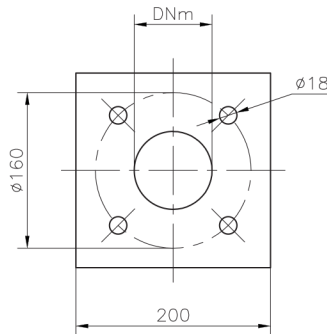

Model Modello	DNa	DNm	a	L1	Booster	By-pass	Motor/Motore (1)		
					kg	kg	kW	Frame	kg
73	G 3	80/3"	160	335	77	18	1,5	90	13
103	G 3	80/3"	190	365	84	18	2,2	90	16

(1) Not certified dimensions and weights.
 They may vary according to installed motor manufacturer
 (1) Dimensioni e pesi in funzione della marca del motore installato.