

pompetravaini

(Rev. 2.0_10-2010)

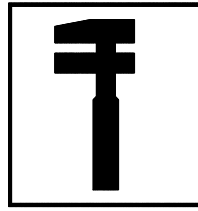

DISASSEMBLY & ASSEMBLY INSTRUCTIONS SINGLE STAGE CENTRIFUGAL PUMPS

TC...

MCU-...

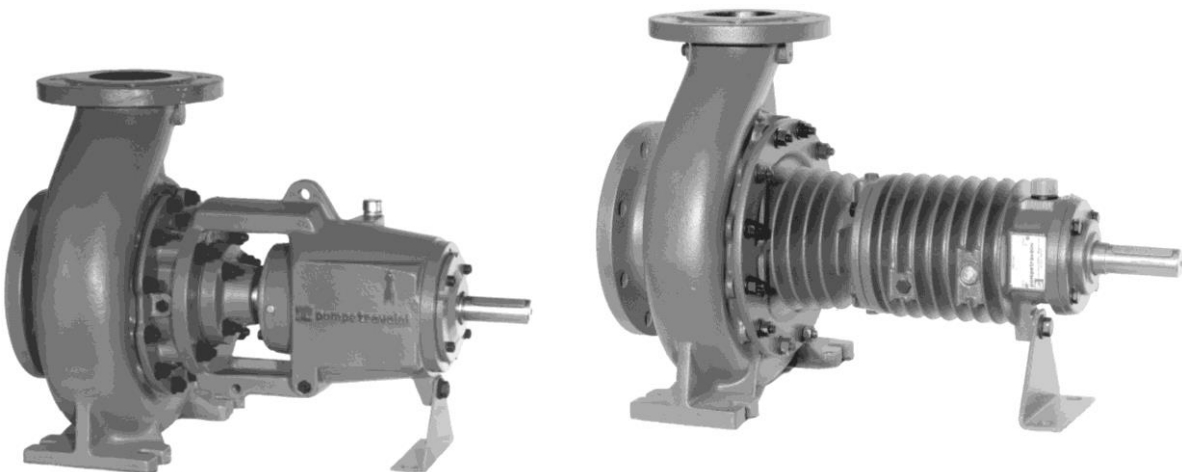

INTRODUCTION

These instructions are for the maintenance personnel for maintenance and/or repair of the indicated pump series. Disassembly and assembly require expertise and knowledge of the procedures, therefore the work must be carried out by qualified personnel. These instructions must be carefully read and understood in conjunction with the section drawings and tables contained in the manual and enclosed, prior to attempt any work on the pumps. For safety, installation and maintenance instructions consult the manual "INSTALLATION & OPERATING INSTRUCTIONS FOR CENTRIFUGAL PUMPS" attached to the pump at time of shipment. Consult also any other attached instructions for accessories and/or components included with the pumps such as mechanical seals, heat exchangers, flushing systems, instrumentation, etc. Before operating or working on the pump it is recommended to adopt safety precautions wearing safety attire (hat, glasses, gloves, shoes, etc.) and have ready the necessary tools required for the work to be done.

Do not subject the pump or its components to sudden mechanical impacts and /or distortions.

Do not damage or scratch the sealing faces. Pay particular attention not to damage flat gaskets and O-Rings. Careful not to leave foreign matters such as moults, screws, washers, rags, etc. in the pump.

When requesting spare parts or technical information for the pump, always quote the pump model number and serial number which is printed on the pump nameplate: therefore it is recommended not to remove the pump nameplate or, in case this action will be necessary, write the serial number on the pump (for example on the flange).

Should additional information be required, please do not hesitate to contact POMPETRAVAINI or the closest representative. Should there be any difficulties in repairing the pump, it is recommended to send the pump for repair to POMPETRAVAINI or the local authorised representative.

Pump repairs and/or service carried out by customer or unauthorised personnel are not guaranteed by POMPETRAVAINI or by its subsidiaries.

Note: Pump parts list identify all pump components by item number (VDMA) in connection with the sectional drawings.

All drawings are for reference purpose and not are certified for construction, however should additional information be required, contact POMPETRAVAINI or its closest representative.

INDEX

- 1 - **Steps to be followed prior to pump disassembly**
- 2 - **Disassembly and assembly of pumps series TCH - TCT - TCA & MCU-CH / CHT / CHA group 1 - 2 - 3**
 - 2.1- *Disassembly*
 - 2.2- *Assembly*
- 3 - **Disassembly and assembly of pumps series MCU-CH group 3 NS and 4 NS**
 - 3.1- *Disassembly*
 - 3.2- *Assembly*
- 4 - **Disassembly and assembly of pumps series TCD and MCU-OD**
 - 4.1- *Disassembly*
 - 4.2- *Assembly*
- 5 - **Mechanical seals assembly**
 - 5.1- *Pumps series TCH - TCT - TCA - MCU-CH - MCU-CHT - MCU-CHA*
 - 5.2- *Pumps series TCD - TCD/SP - MCU-OD - MCU-OD/SP*
- 6 - **Replacing the packing rings**
- 7 - **Spare parts**
- 8 - **Section drawings and typical options**
- 9 - **Nomenclature of pump parts**
- 10 - **Engineering tables**



The liquids handled by the pumps and also their parts could be potentially dangerous for persons and environment: provide their eventual disposal in conformity with the laws into force and a proper environment management.



The present manual is not assigned for pumps subjected to the ATEX 94/9/CE directive. In case the pump is assigned in environments subjected to the application ATEX 99/92/CE directive or in case the pump is provided with a nameplate indicating the ATEX stamp, it is strictly forbidden proceed to start up the pumps but necessary to consult POMPETRAVAINI for clarifications.

For pumps subjected to the ATEX 94/9/CE directive it is available a dedicated integrative manual.

1 - STEPS TO BE FOLLOWED PRIOR TO PUMP DISASSEMBLY

Should pump repairs be required, it is recommended to acquire full familiarity of the procedures to be followed by studying these instructions and the "Operating Manual for Centrifugal Pumps".



FOLLOW THE SAFETY INSTRUCTIONS LISTED UNDER CHAPTER 2 OF THE AFORE MENTIONED OPERATING MANUAL.

It is important to adhere to the following before working on the pump:

- use the appropriate steps to stop the pump
- close the isolating valves at suction and discharge piping
- wear the safety clothing (hard hat, safety glasses, gloves, safety booths, etc.)
- disconnect the electrical power to the motor and all the electrical instrumentation and, if necessary, disconnect the electrical cables
- if the pump is handling hot liquids, let it cool down to ambient temperature
- drain the pump casing through by removing the drain plugs, rinse the pump with neutral liquid, if required
 - adopt all safety precautions when the pump handles hazardous liquids, pollutant or toxic; these liquids as well as the liquid used for rinsing the pump must be collected and disposed of with the maximum caution and always in compliance with the local safety regulations.



To remove the pump and the motor (if required) from the installation proceed as follows:

- remove the bolts on the suction and discharge flanges
- disconnect any flushing lines, accessories and/or instrumentation connected to the pump assembly
- remove the coupling guard
- remove the coupling spacer, if present
- remove the motor, if necessary, by removing the anchor bolts from motor feet or from the motor flange in the case of monoblock assemblies
- remove the pump by removing the bolts from the pump's feet
- disconnect the pump from the installation with caution, do not damage any components
- refer to the "Operating manual for centrifugal pumps" for instructions on transporting the pump.

2 - DISASSEMBLY AND ASSEMBLY OF PUMPS SERIES

TCH - TCT - TCA

MCU-CH / CHT / CHA group 1 - 2 - 3

2.1 - DISASSEMBLY

(See the section drawings from fig. 2 to fig. 11 of chapter 8).

Remove the oil from the bearing frame through the draining plug VDMA 903.4 (dispose of the oil in compliance with the local safety regulations).

Remove the bolts from the studs VDMA 902.2, this allows removal of the rotor from the pump casing. Pumps with vortex impeller (series TCT and MCU-CHT) are fitted with spacer ring VDMA 110 which must be removed from the casing or from the casing cover.

Remove the impeller nut VDMA 922 (for cast iron construction) or VDMA 925 (for stainless steel construction) so that the impeller VDMA 230 can then be removed from the shaft VDMA 210, remove then the key VDMA 940.2.

Pumps with open impeller (series TCA and MCU-CHA) are fitted with two wear plates VDMA 135 and 135.2; to remove the wear plates the screws VDMA 900.1 and 900.2 must be removed.

Remove the bolts from studs VDMA 902.1, if pump is fitted with mechanical seal, remove the bolts from the studs VDMA 902 of the seal cover and separate the casing cover VDMA 161 from frame VDMA 330.

The seal stationary face if fitted in the seal cover, remove it if replacement is required.

For pumps with packed stuffing box it is required to remove the nuts from studs VDMA 902.3, remove the seal gland VDMA 452 attached to the cooling cover VDMA 165 and finally remove the packing rings VDMA 461.

Removal of mechanical seal(s) and of packing should be carried out carefully to prevent damaging any of the various components. Remove the shaft sleeve VDMA 524 with the seal rotating element still on the sleeve together with the locating ring VDMA 485. If the locating ring requires replacement be sure to mark its location prior to removal.

For "CARTRIDGE" type mechanical seal insert the seal spacers prior to removal of the seal. The seal spacers will block the seal with its sleeve, loosen then the set screws that lock seal sleeve to the pump shaft, remove the nuts from the studs that attach the seal flange to the pump and slide the Seal Cartridge out.

To completely disassemble the bearing frame proceed as described below.

Remove the splash ring VDMA 507. With a gear puller remove the half coupling from the pump shaft and the key VDMA 940. When dealing with Monoblock design remove also the lantern VDMA 341. Remove the two bearing covers VDMA 360.1 and/or 360.2 complete of radial seal rings VDMA 421 and 421.1 or 421.5.

Remove the retaining rings VDMA 932 or bearing nut VDMA 923, applying a slight pressure push the shaft out, together with the bearings, toward the free end. The pressure should be such that the axially fixed bearing will be removed from the shaft. The last bearing should be removed from the shaft with the help of a gear puller.

2.2 - ASSEMBLY

Visually and dimensionally examine the components to be replaced. Verify the integrity of the component and quantify the degree of wear (for the main dimensions see tab. 2 - 3 - 4 - 6 of chapter 10). When new parts are required always insist on original parts from POMPETRAVAINI.

In case of doubts or should there be any questions regarding the above, do not hesitate to contact POMPETRAVAINI or the nearest authorised representative.

To replace the wear ring VDMA 502 it is required to loosen the set screws VDMA 904, using a puller or in the event of difficulty the wear ring can be machined on a lathe.

Pumps with open impeller (series TCA and MCU-CHA) must have the proper clearance between the wear plates and the impeller (contact the factory for specific values).

It is good practice to replace all gaskets and packing rings (even if they do not show evidence of defects), bearings and mechanical seals that show wear grooves and excessive tolerances.

Clean each components using suitable cleaning agents and compatible with the materials of construction. Bearings must be decreased with a solvent such as Naphtha, allow them to dry and then lubricate with oil. To help with the bearing installation it is recommended to pre-heat the bearings to approximately 80 °C.

If there are no complications and the components do not show any defects, wear and scratches on the sealing faces, the assembly steps will be by proceeding the reverse of the disassembly.

Fitting of mechanical seals or packing rings are described in chapters 5 or 6. See chapter 10, tab. 2 - 3 - 4, for dimensions details.

During assembly the fitting of the various components must be free of interference and damages.

For a positive placement of the gaskets it is suggested to use a compatible fluid (example oil) to help keeping the gaskets in the sealing area.

See fig. 17 of chapter 10 for torque values of bolts and screws.

After the assembly it is suggested to hydrotest the pump for leakage. The test pressure should be at least 1.2 times the maximum working pressure ma not less than 4 bar. The seal chamber of pumps fitted with double back to back mechanical seals, should also be pressurised.

3 - DISASSEMBLY AND ASSEMBLY OF PUMPS SERIES MCU-CH group 3 NS and 4 NS

3.1 - DISASSEMBLY

(See the section drawings of fig. 12 - 13 - 14 of chapter 8).

Drain the oil from the bearing frame by removing the drain plug VDMA 903.4.

Remove the bolts from the studs VDMA 902.2 so that the rotor may be removed from the pump.

Place the rotor assembly in the vertical position with the drive end toward the bottom.

Loosen the impeller nut VDMA 925 and remove the impeller VDMA 230 from the shaft VDMA 210. Remove the bolts VDMA 914 and remove cover VDMA 471.1 (pay attention to the stationary seal element that is left in the cover, for back to back double seal arrangement).

Remove the shaft sleeve VDMA 524 with the seal rotating element still on the sleeve together with the locating ring VDMA 485. If the locating ring requires replacement be sure to mark its location prior to removal.

For pumps with packed stuffing box it is required to remove the nuts from studs VDMA 902.3, remove the seal gland VDMA 452 attached to the cooling cover VDMA 165 and finally remove the packing rings VDMA 461.

Removal of mechanical seal(s) and of packing should be carried out carefully to prevent damaging any of the various components. Remove the cover VDMA 161 and the mechanical seal cover VDMA 471 or the seal gland VDMA 452. The seal stationary element is still in the seal cover, remove it if replacement is required.

For "CARTRIDGE" type mechanical seal insert the seal spacers prior to removal of the seal. The seal spacers will block the seal with its sleeve, loosen then the set screws that lock seal sleeve to the pump shaft, remove the nuts from the studs that attach the seal flange to the pump and slide the Seal Cartridge out.

To completely disassemble the bearing frame proceed as described below.

Remove the splash ring VDMA 507. With a gear puller remove the half coupling from the pump shaft and the key VDMA 940. Remove the screws VDMA 901.2, remove the casing cover VDMA 163 together with the outer ring of the roller bearing VDMA 323. In the event the outer ring of the roller bearing requires replacement, it is necessary to remove the snap ring VDMA 932.3 and then utilise the external extraction holes.

Rotate the bearing frame with the drive shaft end upward, remove screws VDMA 901 and bearing cover VDMA 360.2. Remove the shaft VDMA 210 with bearings VDMA 320. To replace these bearings remove first the bearing nut VDMA 923.

3.2 - ASSEMBLY

Assembly procedures are same as given under paragraph 2.2 (for components type and dimensions see tab. 5 of chapter 10).

4 - DISASSEMBLY AND ASSEMBLY OF PUMPS SERIES

TCD and MCU-OD

4.1 - DISASSEMBLY

(See the section drawings of fig. 15 and 16 of chapter 8).

Drain the oil from the bearing frame by removing the drain plug VDMA 903.4.

Remove the bolts from the studs VDMA 902.2 so that the rotor may be removed from the pump.

Remove the impeller nut VDMA 922 (for Cast Iron construction) or VDMA 925 and 922 (for Stainless Steel construction) and remove impeller VDMA 230 from the shaft VDMA 210, remove key VDMA 940.2. Remove screws VDMA 900.1 and cooling plate VDMA 167.

Remove the screws VDMA 901.1 or, for /SP construction, the bolts from studs VDMA 902.1.

Remove the casing cover VDMA 163, loosen the set screws on the rotating element of the mechanical seal, remove both elements of the mechanical seal. For the /SP design remove also the reducing flange VDMA 184.

To completely disassemble the bearing frame proceed as described below.

With a gear puller remove the half coupling from the pump shaft and the key VDMA 940.

Remove screws VDMA 901 and bearing cover VDMA 360.

Remove the retaining rings VDMA 932.3, push the shaft VDMA 210 out toward the free end, together with the bearing VDMA 320.1. Remove the snap ring VDMA 932 and the bearing VDMA 320.1.

4.2 - ASSEMBLY

For assembly procedures see paragraph 2.2 in combination with the tab. 1 below that contains the specific components dimensions pertaining this pump series only.

Tab. 1 - Pumps series **TCD - MCU-OD and /SP**

PUMP MODEL	BEARINGS TYPE		SHAFT SEAL RINGS TYPE	MECHANICAL SEAL Ø (mm)	OIL KG.
25 - 32 - 40 - 50 - 65/ 125	Seal side	Drive side	N°1 AS25357 (25x35x7)	Ø30	0,20
25 - 32 - 40 - 50 - 65 - 80 / 160	N°1 6206 C3 (30x62x16)	N°1 6305 C3 (25x62x17)			
25 - 32 - 40 - 50 / 200	N°2 6308 C3 (40x90x23)				
65 - 80 - 100 / 200	N°2 6308 C3 (40x90x23)		N°1 AS35477 (35x47x7)	Ø40	0,40
40 - 50 - 65 - 80 / 250					

5 - MECHANICAL SEALS ASSEMBLY

5.1 - Pumps series TCH - TCT - TCA - MCU-CH - MCU-CHT - MCU-CHA

NOTE: Where available, read the specific instructions of the used mechanical seal as well as the following information.

Mechanical seal different than the one originally fitted in the pump may be used. Note however, that the primary dimensions must be the same and the material of construction must be suitable with the liquid handled. For more information and the assembly dimensions pls contact POMPETRAVAINI or its closest representative.

Clean the stationary seal element removing encrustation, oxidation and deposit of the flushing liquid. Lubricate the seat and the elastomers of the stationary seat with oil that is compatible with the seal elastomers. Push the prepared seal stationary seat in the seal cover VDMA 471 or casing cover VDMA 161, be sure to centre the anti-rotating pin is installed.

Pumps fitted with double mechanical seals will have the outboard (drive end) installed as above, while the internal seal (impeller side) will have the stationery seat fitted in the casing cover VDMA 161 for the case of double back to back seals, or in the seal retainer VDMA 542 in the case of double seals in series (tandem).

Clean the shaft sleeve VDMA 524 with extra fine emery cloth. Cleaning strokes should be axially.

Install the seal locating ring VDMA 485, if previously removed, in the original location. If the mechanical seal is fitted with set screws on its collar the seal locating ring VDMA 485 may not be present.

CAUTION! The position of the seal locating ring will vary with the seal working length.

In the event the new mechanical seal has a working length different than the original seal, it will be required to relocate the seal locating ring accordingly.

Lubricate with compatible oil the sleeve and the elastomers of the seal rotating element.

Push the seal rotating element on the sleeve helping with a rotating motion until it rests against the locating ring VDMA 485. Tighten set screws if fitted in the mechanical seal.

For pumps having double mechanical seals back to back, the above procedure apply for both seal rotating elements. Should the mechanical seals be with conical single spring pay particular attention to their rotation direction.

Pumps fitted with double mechanical seals in series (tandem), will require fitting the rotating seal element impeller side (inside seal), followed by the seal insert VDMA 542 with the stationary seal face element, locate the snap ring VDMA 932.1 on the sleeve VDMA 524 and fit the rotating element of the external mechanical seal. After these assembly steps,

install the seal cover VDMA 471 on the shaft, the cooling cover VDMA 165 with the studs in place, then all the required gaskets and the pre-assembled shaft sleeve.

Prior to finalise the mechanical seal assembly, already fitted on the shaft sleeve, it is recommended to clean both seal faces with a clean and soft tissue. Finally proceed with the assembly of the complete pump avoiding stress on the seal assembly which could damage the fragile components of the mechanical seal.

“CARTRIDGE” TYPE MECHANICAL SEALS

These type of seals are easy to install because they are pre-assembled on a seal sleeve.

To install the “cartridge” simply slide the assembly over the shaft sleeve or the shaft itself depending upon the design, paying particular attention not to damage the seal O-Ring.

Complete the pump assembly, lock the cartridge flange with the studs, lock the set screws of the seal sleeve on to the shaft or shaft sleeve, remove the sleeve/cartridge spacers that have allowed the correct location of the total seal assembly.

5.2 - Pumps series TCD - TCD/SP - MCU-OD - MCU-OD/SP

Clean the stationary seal element of any encrustations, oxidation or residues from the handled liquid.

Lubricate the seal cavity and the elastomers with a compatible light oil.

Place the bearing frame VDMA 330 in the vertical position with the shaft drive end at the bottom, (in the case of pump /SP the bearing frame should have attached the extension flange VDMA 184), install the seal stationary element with the pertaining O-Rings, the lapped seal face should be at the top, clean the seal face with a soft tissue.

Lubricate the shaft and the Viton booth of the seal rotating element. Clean seal face with a soft tissue and slide the rotating seal element on to the shaft VDMA 210 with the carbon face to the bottom.

Pumps of the Group 1, position the seal rotating element 84.5 mm from the shaft shoulder (against which the impeller VDMA 230 will rest), pumps of the Group 2 this distance should be 109 mm, tighten the set screws to lock the seal to the shaft (see fig. 1).

Place the O-Rings required and install the casing cover VDMA 163 on the bearing frame VDMA 330 (on the extension VDMA 184 for pump design /SP). Tighten the 4 bolts or studs and proceed then with assembling the balance of the pump.

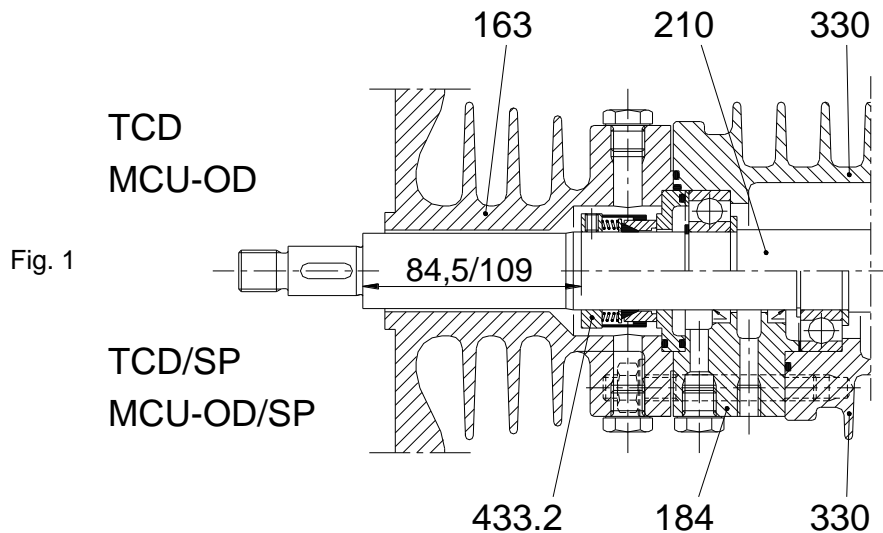

6 - REPLACING THE PACKING RINGS

Replacement of the packing rings can be accomplished without disassembling the pump but proceeding as follows. Remove the nuts on the packing gland studs VDMA 902.3, move the gland packing VDMA 452 as much as possible toward the drive end. Remove with a suitable tool the old packing rings VDMA 461 and the lantern ring VDMA 458. Clean the packing chamber and the shaft sleeve removing any encrustation, oxidation and deposits from the flushing fluid.

Install the packing rings one by one and the lantern ring. Be sure to relocate the lantern ring in the original location and the packing rings should be rotated so that the joints are 90° apart.

Replace the seal gland with the associated adjusting nuts.

In the event the pump has been completely disassembled, it is recommended to fit the casing VDMA 161 with packing rings VDMA 461, lantern ring VDMA 458 and gland packing VDMA 452, then this sub-assembly will be attached to the pump frame. Be careful not to disturb the packing rings while inserting the shaft sleeve on to the shaft.

Alternatively, assembly first the pump and then the stuffing box as discussed above.

7 - SPARE PARTS

When ordering the pump it is good practice to also order the necessary spare parts, especially when there are no stand-by pumps in the installation. This will minimise unnecessary down times in the event of pump failure or routine maintenance. Following spare parts are suggested for each pump size:

1	Impeller
1	Wear ring
1	Shaft assembly
1	Set of bearings
1	Set of mechanical seals or packing
2	Sets of gaskets

However for proper parts management, consult the VDMA 24296 standard that recommends the quantity of spare parts to be stocked in relation to the number of pumps installed.

On the pump nameplate are printed the pump model, the year of manufacture and the pump serial number: always provide this information when requesting spare parts.

Specify also the VDMA number of the required part, as seen on the pump sectional drawing and parts list for proper identification of spare parts.

We recommend the use of original spares: in case this is not respected, POMPETRAVAINI declines any responsibility for eventual damages caused by not original spare parts.

8 - SECTIONAL DRAWINGS AND TYPICAL OPTIONS

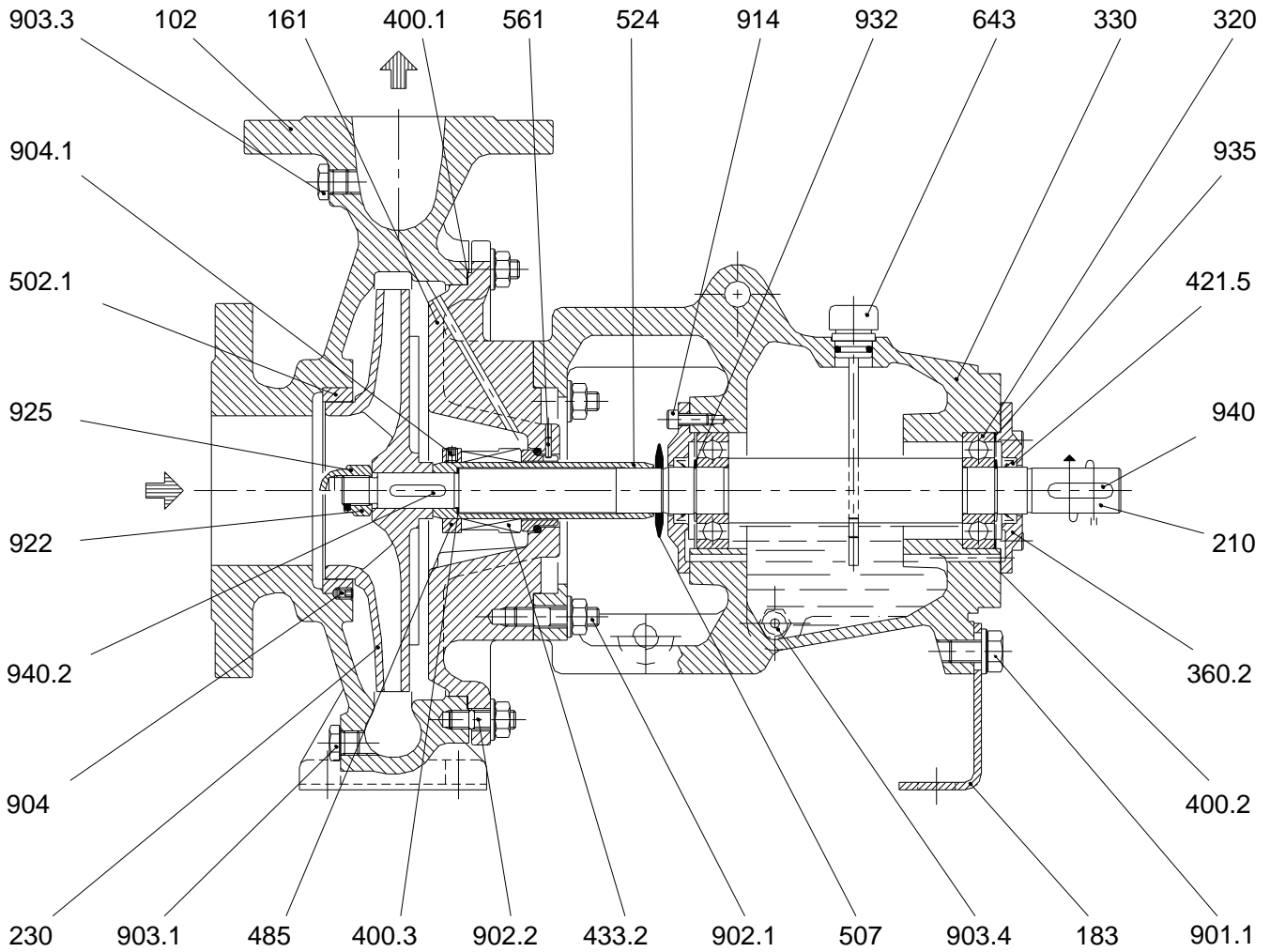

Fig. 2 - Pump series TCH gr. 1 & 2 design /1-C = Single mechanical seal
 NOTE: VDMA 925 applies only to stainless steel design

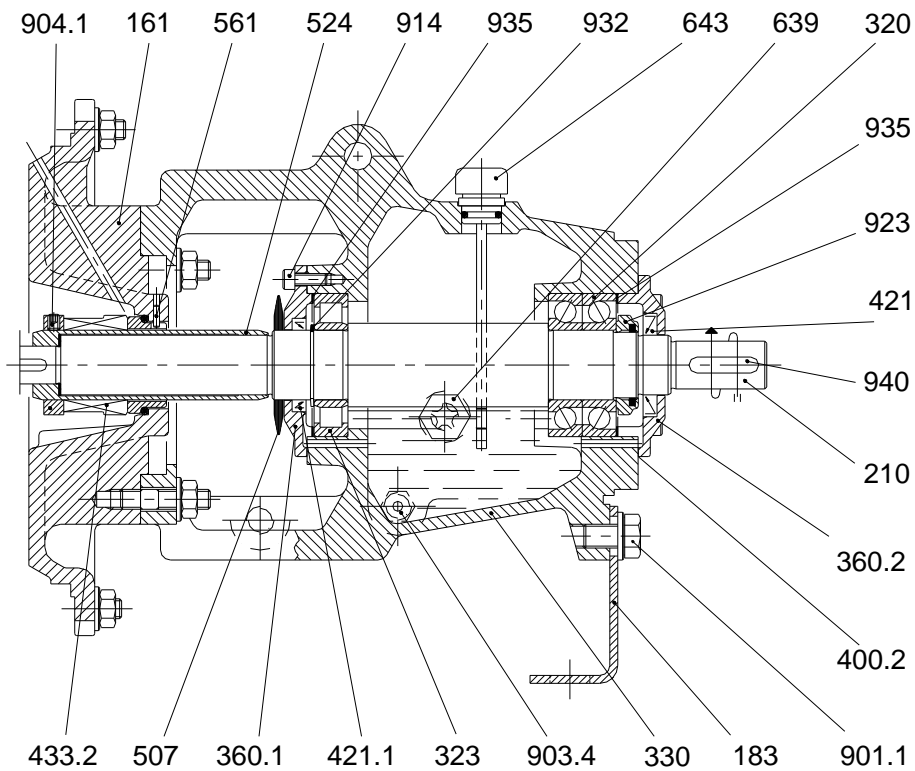

Fig. 3 - Option with oversized bearing frame (design /1X)

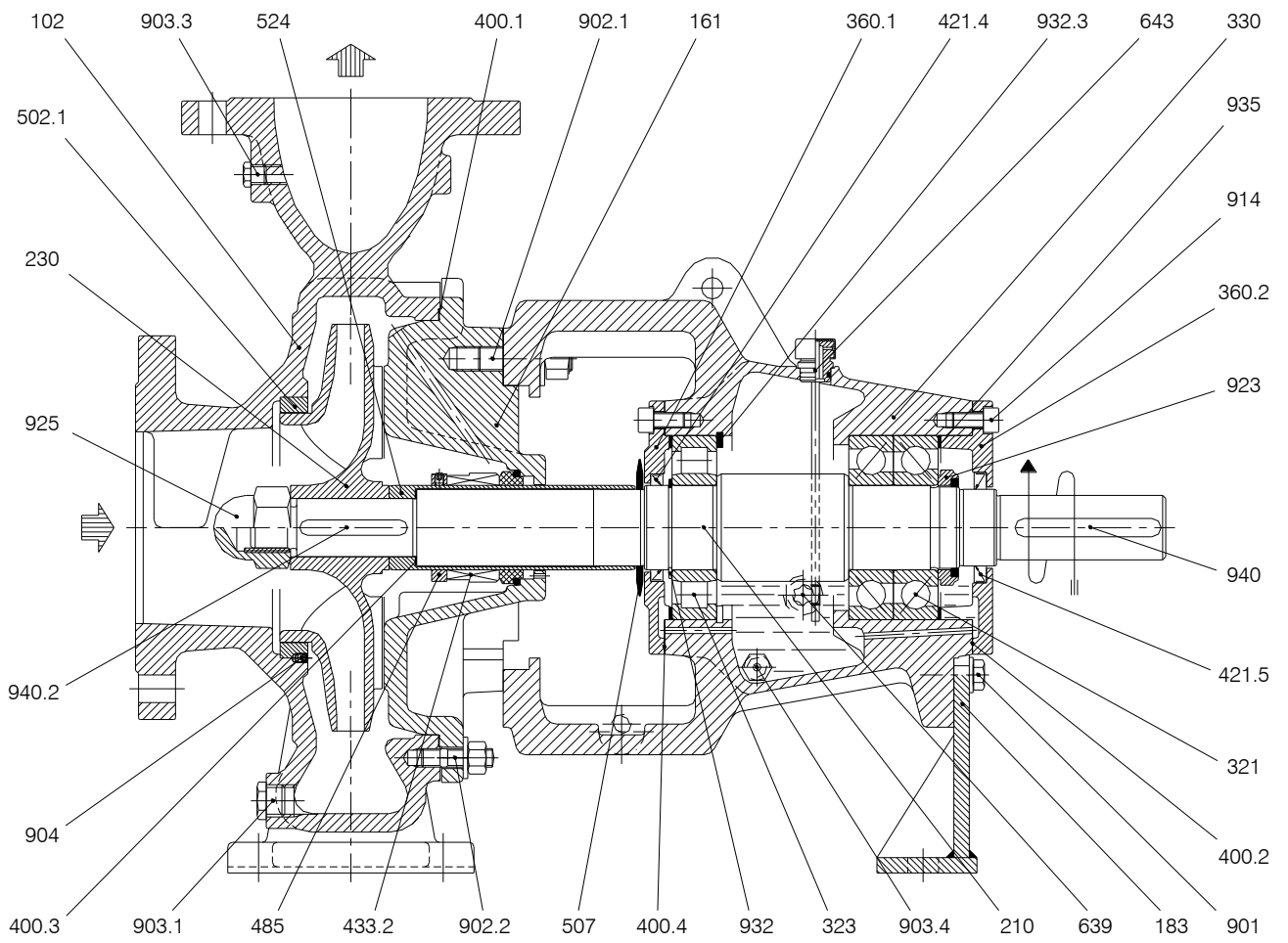

Fig. 4 - Pump series TCH gr. 3 design /1-C = Single mechanical seal

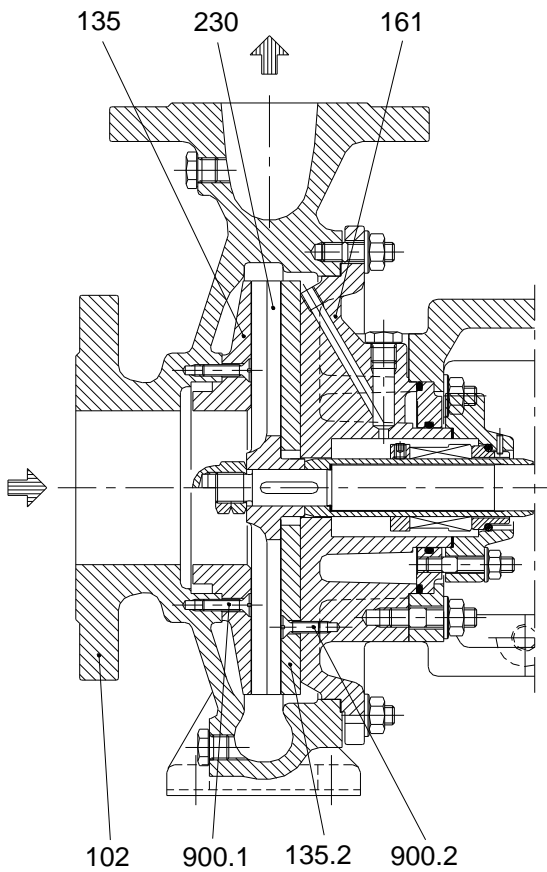

Fig. 5 - Pump series TCA - MCU-CHA
(Impeller fully open)

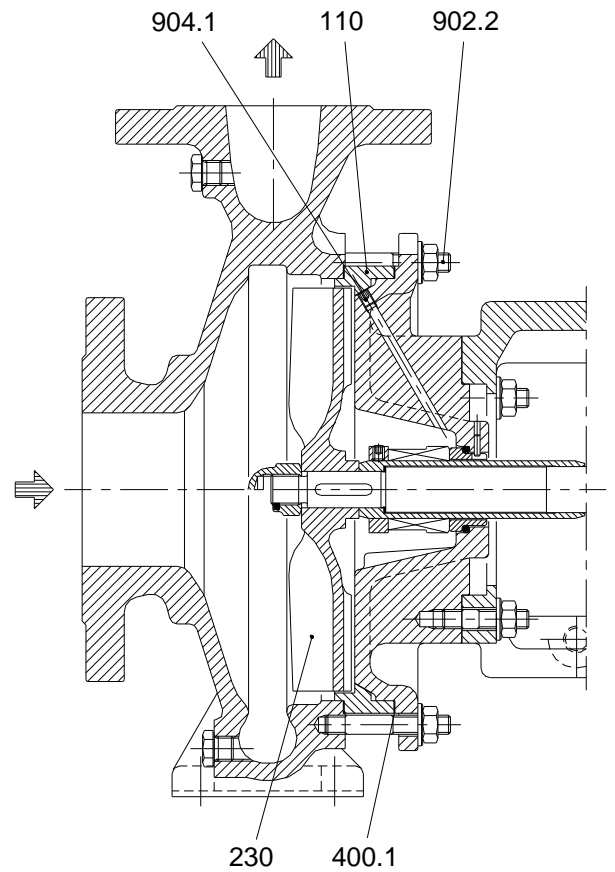

Fig. 6 - Pump series TCT - MCU-CHT
(Vortex impeller)

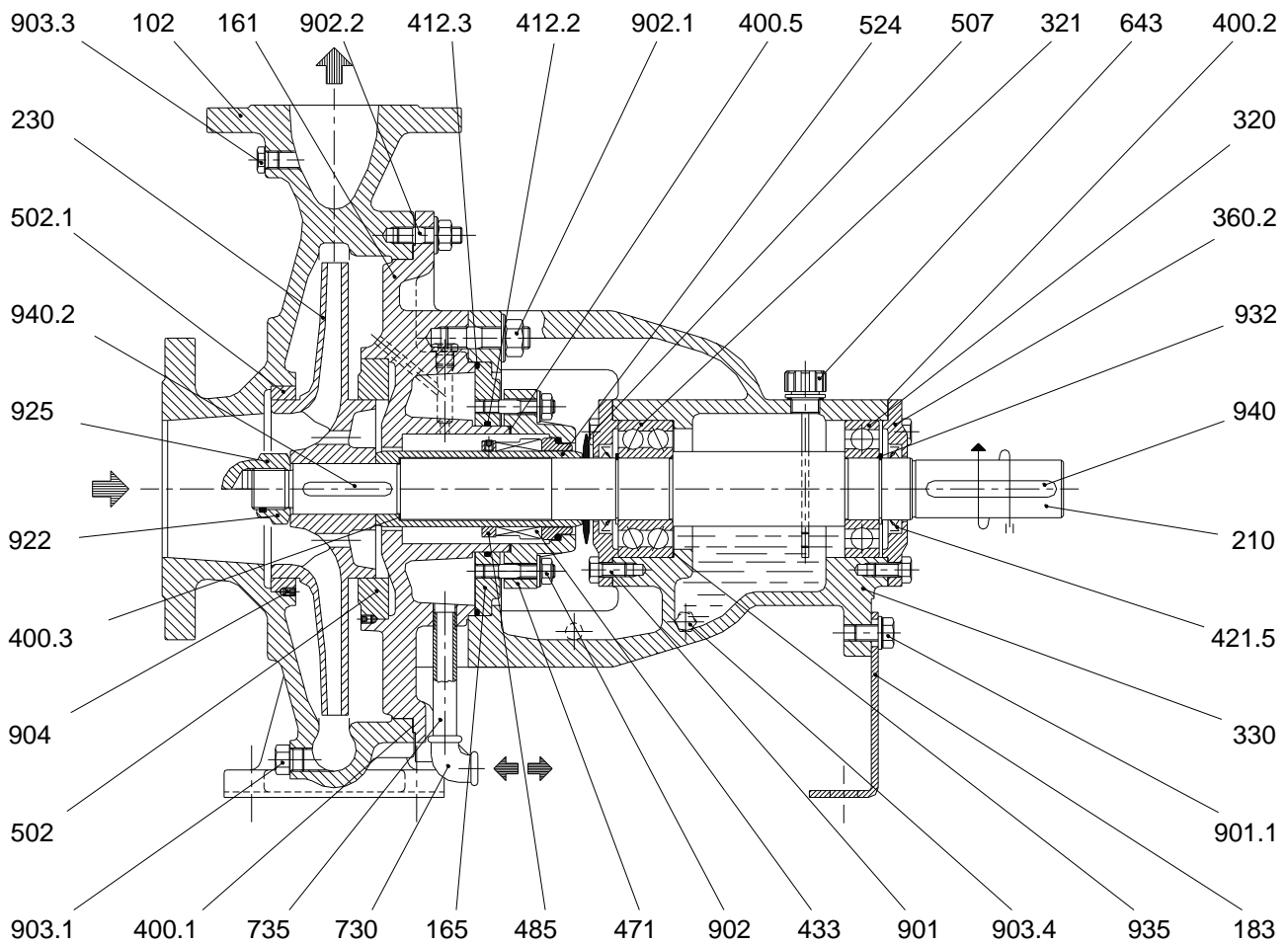

Fig. 7 - Pump series MCU-CH gr. 3 design /R = Single mechanical seal
 NOTE: VDMA 925 applies only to stainless steel design

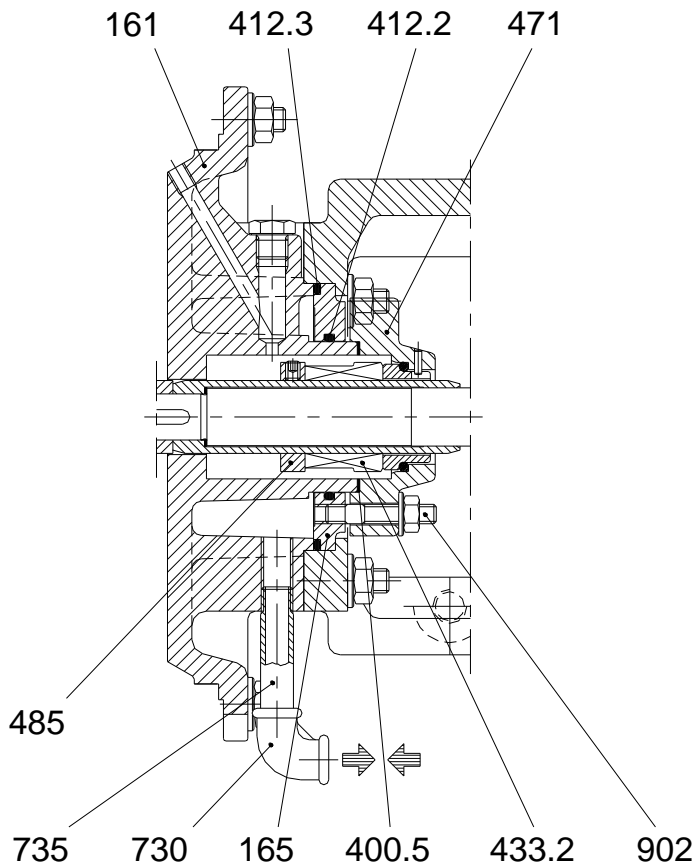

Fig. 8 - Option for design /1-R
 = Single and cooled mechanical seal

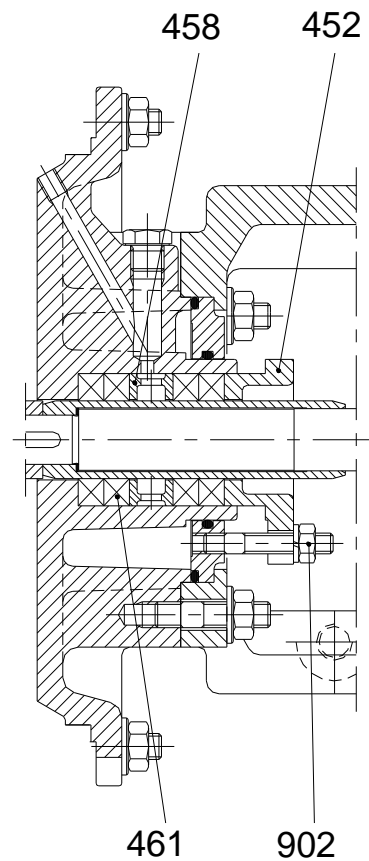

Fig. 9 - Option for design /1-B
 = Packed and cooled stuffing box

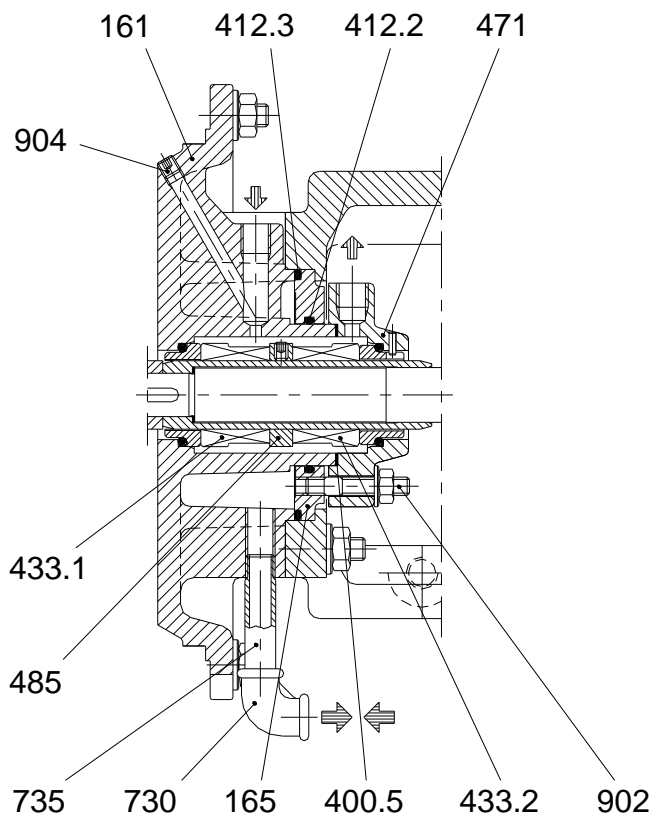

Fig. 10 - Option for design /1-RR
 = Cooled and double mechanical seal
 back to back

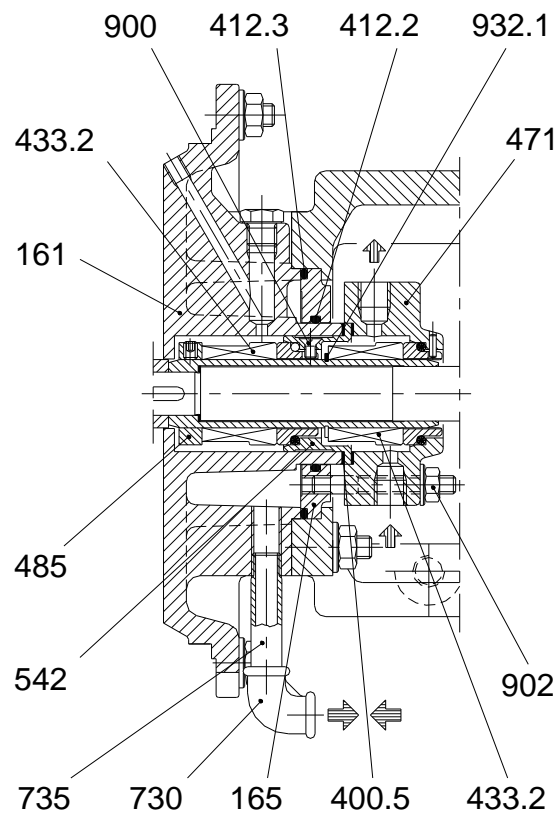

Fig. 11 - Option for design /1-R2
 = Cooled and double mechanical seal
 in series

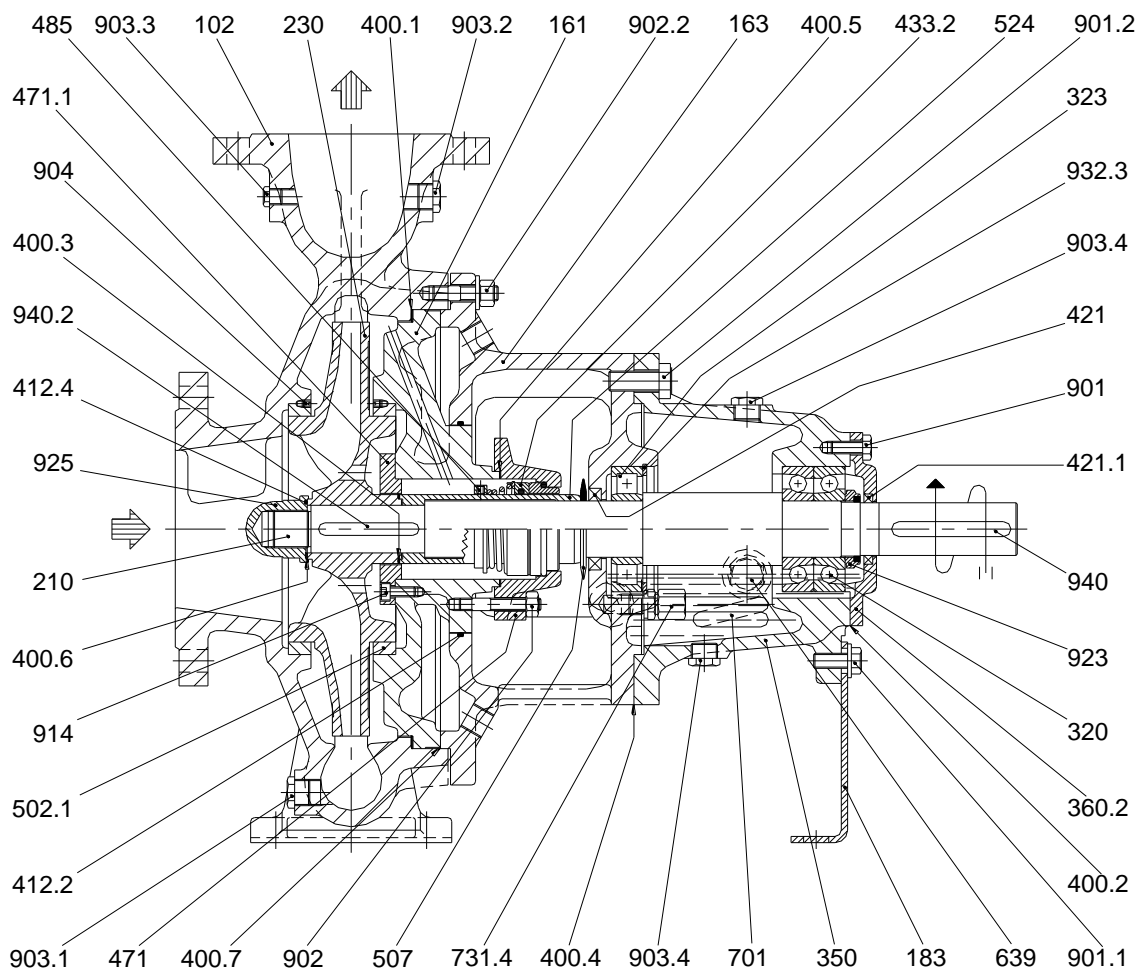

Fig. 12 - Pump series MCU-CH group 3 NS and 4 NS design /R = Single mechanical seal
 NOTE: VDMA 412.4 = New construction - VDMA 400.6 = Old construction

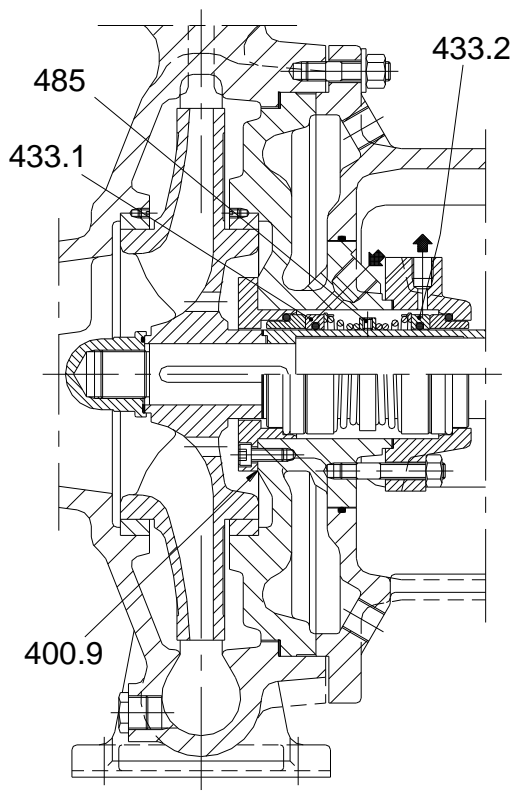

Fig. 13 - Option for design /RR
= Double mechanical seal back to back

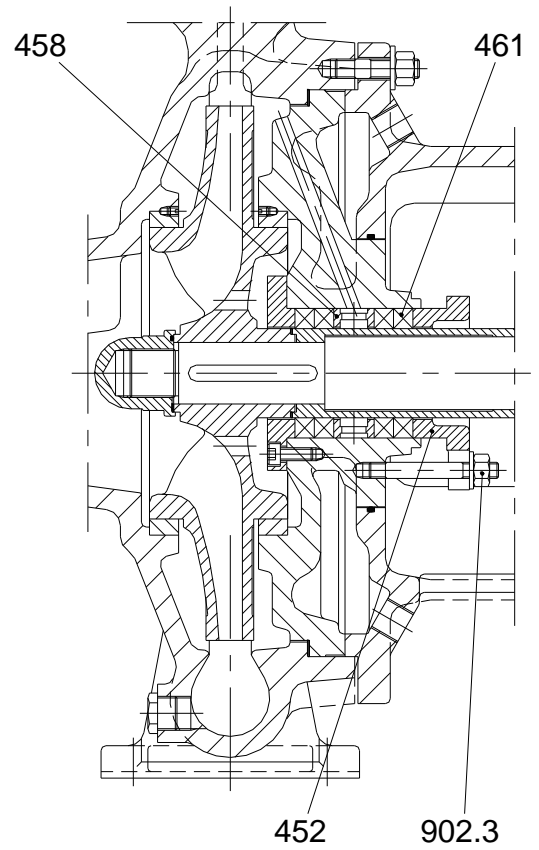

Fig. 14 - Option for design /B
= Packed stuffing box

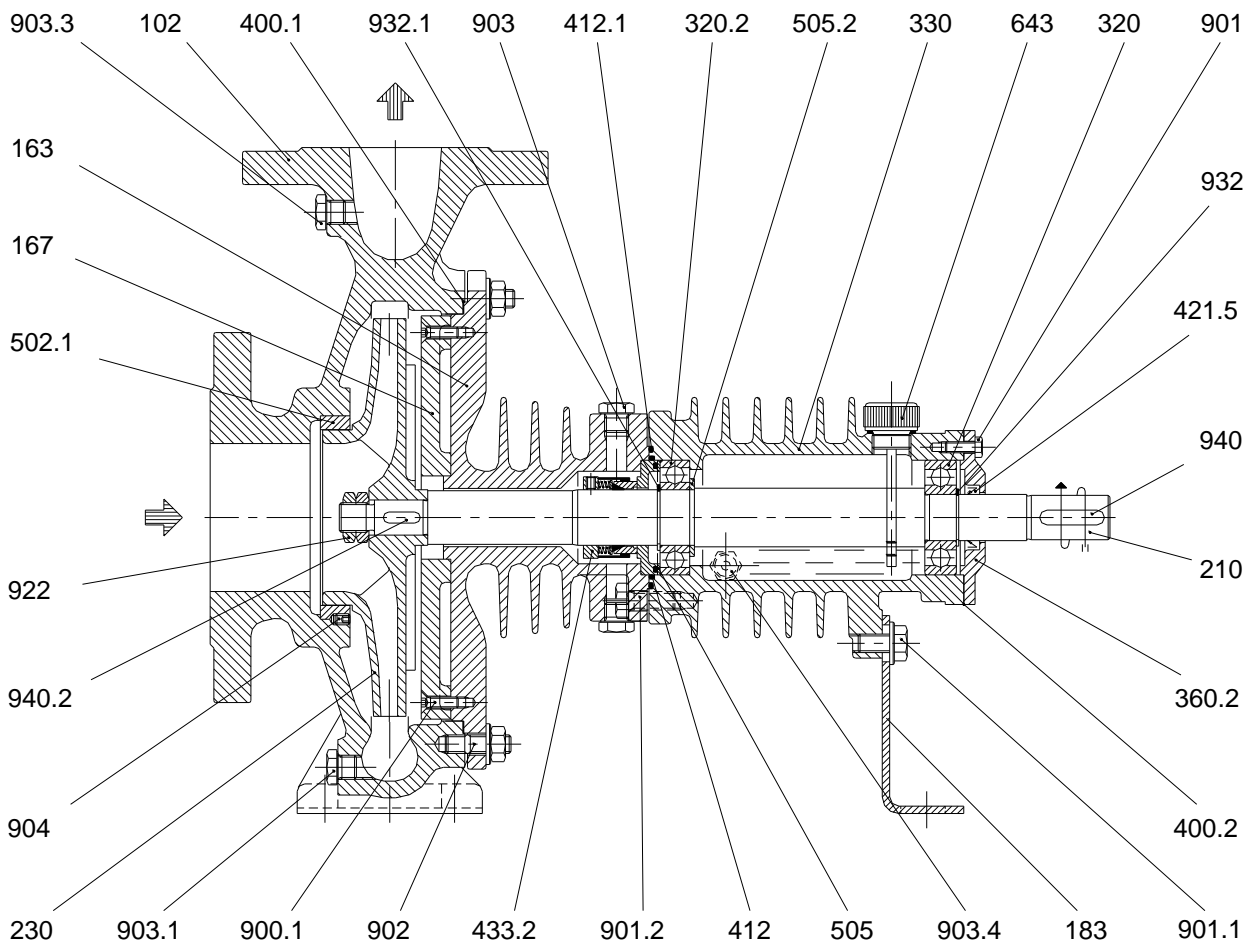

Fig. 15 - Pump series TCD and MCU-OD

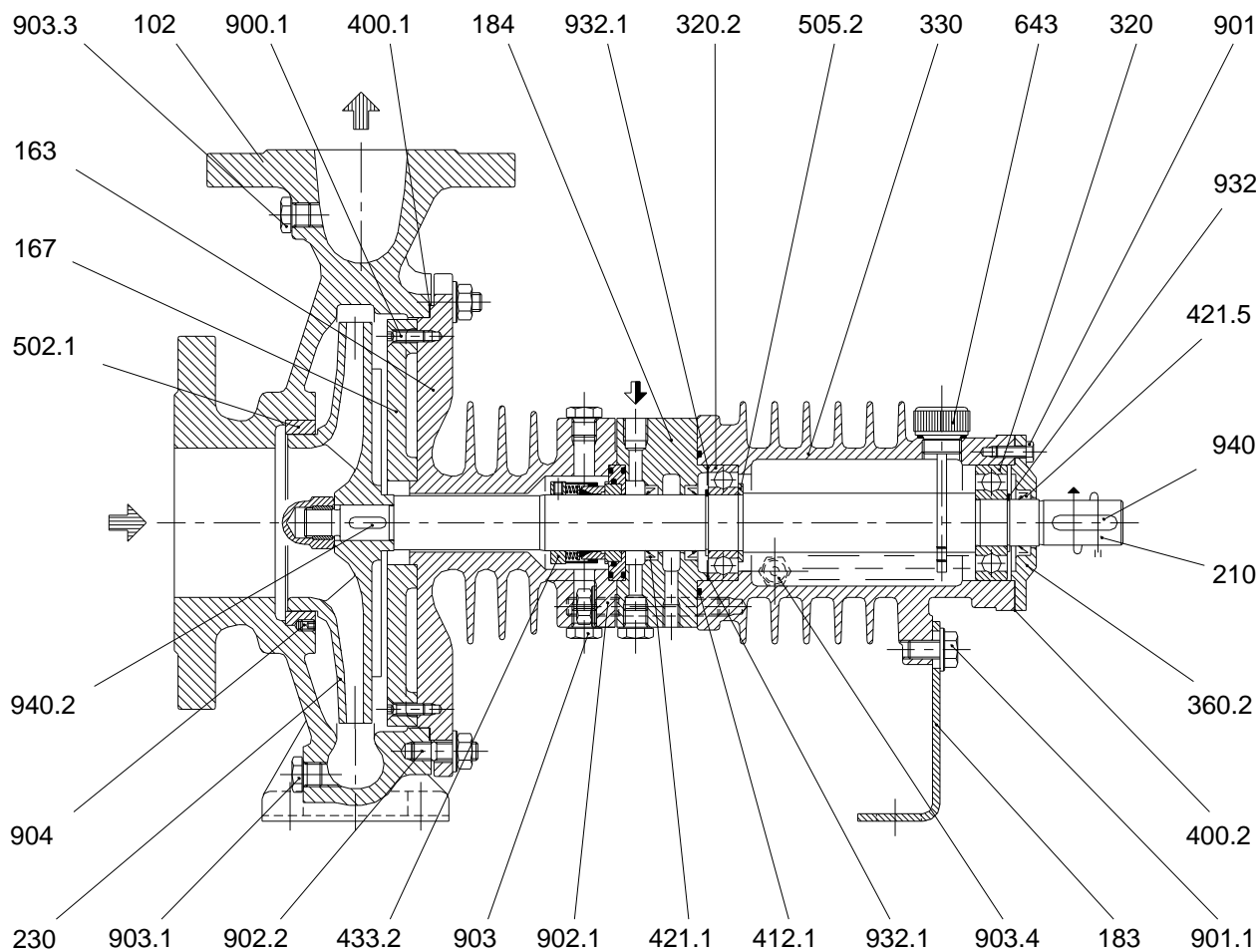

Fig. 16 - Pump series TCD/SP and MCU-OD/SP

9 - NOMENCLATURE OF PUMP PARTS

VDMA N°	DESCRIPTION
102	Suction casing
110	Spacer ring
135...	Wear plate
161	Casing cover
163	Casing cover
165	Cooling cover
167	Cooling plate
183	Support foot
184	Extension flange
210	Shaft
230	Impeller
320...	Ball bearing
321	Ball bearing
323	Roller bearing
330	Bearing frame
350	Bearing frame
360...	Bearing cover
400...	Gasket
412...	O-Ring
421...	Radial seal ring
433...	Mechanical seal
452	Gland packing
458	Lantern ring
461	Packing ring
471...	Mechanical seal cover
485	Seal locating ring

VDMA N°	DESCRIPTION
502...	Wear ring
505...	Spacer ring
507	Splash ring
524	Shaft sleeve
542	Mechanical seal bush
561	Elastic pin
637	Oil filling plug
639	Oil sight gauge
643	Oil dipstick
672	Cock
701	Piping
730	Fitting
731...	Fitting
735	Nipple
900...	Screw
901...	Screw
902...	Stud
903...	Plug
904	Grub screw
914	Screw
922	Locking nut
923	Bearing nut
925	Impeller locking nut
932...	Circlip
935	Elastic ring
940...	Key

Fig. 17 - Torque values for various bolt sizes

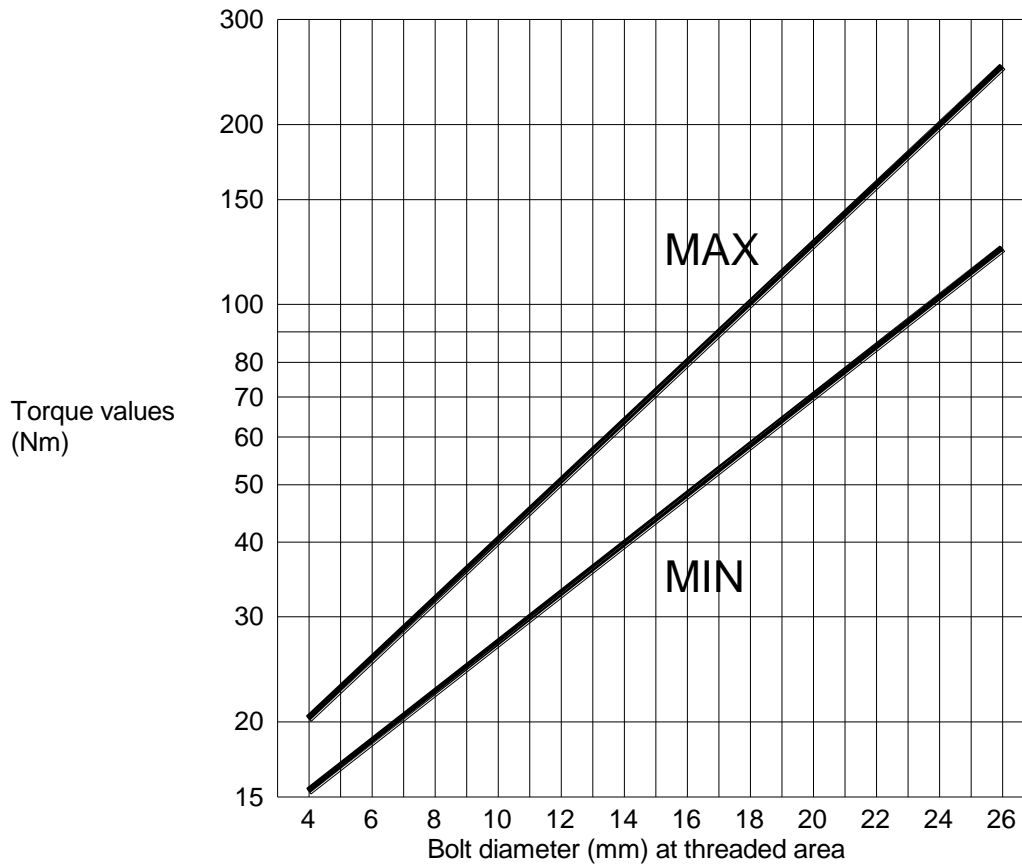

Tab. 2 - Pumps series TCH - TCT - TCA

	PUMP MODEL	BEARINGS TYPE		RADIAL SEAL RINGS TYPE for SHAFT		* MECHANICAL SEAL Ø (mm)		PACKING RINGS Dim. x N° rings (mm)		OIL KG.
		Design /1	Design /1X	Design /1	Design /1X	Design /1	Design /1X	Design /1	Design /1X	
Group 1	25-125	N°2 6305 (25x62x17)	Seal side N°1 NU207 (35x72x17)	N°2 AS25357 (25x35x7)	Seal side N°1 AS35477 (35x47x7)	On sleeve Ø30	On sleeve Ø35	Di = 30 De = 51 H = 10 N° = 4	Di = 35 De = 51 H = 8 N° = 4	0,45
	25-160									
	25-200									
	32-125									
	32-160									
	32-200									
	40-125									
	40-160									
	40-200									
	50-125									
	50-160									
50-200										
Group 2	32-250	N°2 6307 (35x80x21)	Seal side N°1 NU309 (45x100x25)	N°2 AS35477 (35x47x7)	Seal side N°1 AS45658 (45x65x8)	On sleeve Ø45	On sleeve Ø50	Di = 45 De = 70 H = 12 N° = 4	---	0,90
	40-250									
	40-315									
	50-250									
	50-315●									
	65-125									
	65-160									
	65-200									
	65-250									
	80-160									
	80-200									
	80-250									
	100-200									

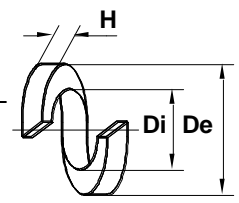

● For dimensions of pumps model TCT 50-315 see pumps model TCT 65-315

* According to DIN 24960 standards

Tab. 3 - Pumps series **TCH/1X gr. 3**

PUMP TYPE	BEARINGS TYPE	RADIAL SEAL RINGS TYPE for SHAFT	* MECHANICAL SEAL Ø (mm)	PACKING RINGS Dim. x N° rings (mm)	OIL KG.
65-315	Seal side N°1 NU301 (55x120x29)	Seal side N°1 AS55708 (55x70x8)	Ø55	Di = 55 De = 80 H = 12 N° = 5	0,75
80-315					
100-250					
100-315					
100-400 NS	Drive side N°2 7311B (55x120x29)	Drive side N°1 AS50728 (50x72x8)			
125-250					
125-315					
125-400 NS					
150-250					

* According to DIN 24960 standards

Tab. 4 - Pumps series **MCU-CH - MCU-CHT - MCU-CHA**

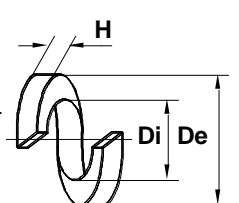
	PUMP MODEL	BEARINGS TYPE	RADIAL SEAL RINGS TYPE for SHAFT	* MECHANICAL SEAL Ø (mm)	PACKING RINGS Dim. x N° rings (mm)	OIL KG.
Group 1	25-125	N°2 6305 (25x62x17)	N°2 AS25357 (25x35x7)	On sleeve Ø30 On shaft Ø24	Di = 30 De = 51 H = 10 N° = 4	0,45
	25-160					
	25-200					
	32-125					
	32-160					
	32-200					
	40-125					
	40-160					
	40-200					
	50-125					
	50-160					
50-200						
Group 2	32-250	N°2 6307 (35x80x21)	N°2 AS35477 (35x47x7)	On sleeve Ø45 On shaft Ø30	 Di = 45 De = 70 H = 12 N° = 4	0,90
	40-250					
	40-315					
	50-250					
	50-315●					
	65-125					
	65-160					
	65-200					
	65-250					
	80-160					
	80-200					
80-250						
100-200						
Group 3	65-315	Seal side N°1 3309 (45x100x39,7)	N°2 AS45658 (45x65x8)	On sleeve Ø55	Di = 60 De = 80 H = 10 N° = 6	0,50
	80-315					
	100-250	Drive side N°1 6309 (45x100x25)				
	125-250					
	150-250					

● For dimensions of pumps model MCU-CHT 50-315 see pumps model MCU-CHT 65-315

Tab. 5 - Pumps series **MCU-CH group 3 NS and 4 NS**

	PUMP MODEL	BEARINGS TYPE	RADIAL SEAL RINGS TYPE for SHAFT	* MECHANICAL SEAL Ø (mm)	PACKING RINGS Dim. x N° rings (mm)	OIL KG.
Gl. 3 NS	100-315	Seal side	Seal side	On sleeve	D _i = 55 D _e = 80 H = 12 N° = 4	1,50
	100-400	N°1 NU309 (45x100x25)	N°1 AS45658 (45x65x8)	Ø55		
	125-315	Drive side	Drive side	On shaft		
	125-400	N°2 7309B/UA (45x100x25)	N°1 AS42567 (42x56x7)	Ø45		
Gl. 4 NS	150-315	Seal side	Seal side	On sleeve	D _i = 70 D _e = 100 H = 14 N° = 4	2,50
	150-400	N°1 NU313 (65x140x33)	N°1 AS55708 (55x70x8)	Ø70		
	200-315					
	200-400	Drive side	Drive side	On shaft		
	250-315	N°2 7313B/UA (65x140x33)	N°1 AS608010 (60x80x10)	Ø60		

* According to DIN 24960 standards

Tab. 6

PUMP MODEL	NOMINAL DIMENSIONS OF WEAR RINGS			DIAMETRAL CLEARANCE in mm BETWEEN IMPELLER NECK AND WEAR RING				IMPELLER MINIMUM BALL SIZE mm
				CASING		CASING COVER		
	A	B	H	DESIGN		DESIGN		
			F - RA	A3	F - RA	A3		
25-125	72	84	13	0,33 - 0,48	0,43 - 0,58			6
25-160	72	84	13	0,33 - 0,48	0,43 - 0,58			6
25-200	72	84	13	0,33 - 0,48	0,43 - 0,58			5
32-125	72	84	13	0,33 - 0,48	0,43 - 0,58			6
32-160	72	84	13	0,33 - 0,48	0,43 - 0,58			5
32-200	72	84	13	0,33 - 0,48	0,43 - 0,58			5
32-250	85	97	13	0,44 - 0,59	0,74 - 0,89			6
40-125	85	97	13	0,34 - 0,49	0,44 - 0,59			10
40-160	85	97	13	0,34 - 0,49	0,44 - 0,59			7,5
40-200	85	97	13	0,34 - 0,49	0,44 - 0,59			6
40-250	95	110	16	0,44 - 0,59	0,74 - 0,89			6,5
40-315	95	110	16	0,44 - 0,59	0,74 - 0,89			8
50-125	95	110	16	0,34 - 0,49	0,44 - 0,59			16
50-160	95	110	16	0,34 - 0,49	0,44 - 0,59			13
50-200	95	110	16	0,34 - 0,49	0,44 - 0,59			9
50-250	105	120	16	0,44 - 0,59	0,74 - 0,89			5
50-315	105	120	16	0,44 - 0,59	0,74 - 0,89			7,5
65-125	105	120	16	0,44 - 0,59	0,74 - 0,89			20,3
65-160	120	135	16	0,44 - 0,59	0,74 - 0,89			18
65-200	120	135	16	0,44 - 0,59	0,74 - 0,89			14
65-250	120	135	16	0,44 - 0,59	0,74 - 0,89			12
65-315	130	150	18	0,44 - 0,61	0,84 - 1,01			10
65-315	130	190	26			0,44 - 0,61	0,84 - 1,01	10
80-160	135	150	16	0,44 - 0,61	0,74 - 0,91			25
80-200	135	150	16	0,44 - 0,61	0,74 - 0,91			21
80-250	135	150	16	0,44 - 0,61	0,74 - 0,91			15
80-315	140	160	18	0,44 - 0,61	0,84 - 1,01			13
80-315	140	190	24			0,44 - 0,61	0,84 - 1,01	13
100-200	150	170	18	0,44 - 0,61	0,74 - 0,91			27
100-250	150	170	18	0,44 - 0,61	0,84 - 1,01			18
100-250	150	200	22			0,44 - 0,61	0,84 - 1,01	18
100-315	180	200	20	0,44 - 0,61	0,84 - 1,01	0,44 - 0,61	0,84 - 1,01	14,5
100-400	180	200	20	0,44 - 0,61	0,84 - 1,01	0,44 - 0,61	0,84 - 1,01	12
125-250	180	200	20	0,44 - 0,61	0,84 - 1,01	0,44 - 0,61	0,84 - 1,01	30
125-315	200	220	18	0,45 - 0,62	0,85 - 1,02	0,45 - 0,62	0,85 - 1,02	24
125-400	200	220	18	0,45 - 0,62	0,85 - 1,02	0,45 - 0,62	0,85 - 1,02	15
150-250	215	235	20	0,45 - 0,62	0,85 - 1,02	0,45 - 0,62	0,85 - 1,02	48
150-315	232	252	22	0,45 - 0,62	0,85 - 1,02	0,45 - 0,62	0,85 - 1,02	32
150-400	232	252	22	0,45 - 0,62	0,85 - 1,02	0,45 - 0,62	0,85 - 1,02	25
200-315	262	282	22	0,46 - 0,64	0,86 - 1,04	0,46 - 0,64	0,86 - 1,04	48
200-400	262	282	22	0,46 - 0,64	0,86 - 1,04	0,46 - 0,64	0,86 - 1,04	34
250-315	312	332	22	0,46 - 0,64	0,86 - 1,04	0,46 - 0,64	0,86 - 1,04	68

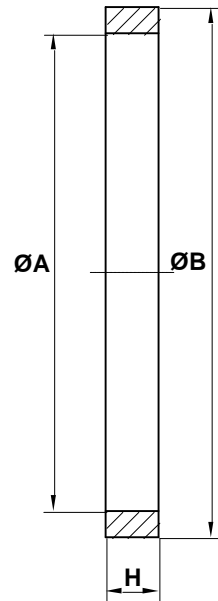

(Blank page)

(Blank page)

NOTES

PUMP model	Serial Number	Computer Number	Year of manuf.
---------------------	------------------------	--------------------------	-------------------------

LIQUID handled	Capacitym ³ /h	Suction Pressurem	Discharge Press.m	Temperature°C
<input type="checkbox"/> Lethal <input type="checkbox"/> Toxic <input type="checkbox"/> Noxious <input type="checkbox"/> Corrosive <input type="checkbox"/> Irritant <input type="checkbox"/> Malodorous <input type="checkbox"/>				
<input type="checkbox"/> Clean <input type="checkbox"/> Dirty <input type="checkbox"/> With suspended parts		Spec. Gravity.....	Viscosity.....	PH.....

TOTAL WEIGHT
.....KGs.

MAXIMUM DIMENSIONS

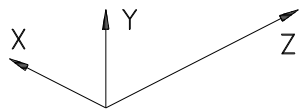

X =cm
Y =cm
Z =cm

NOISE (measured at 1 m)

Pressure =dB(A)
Power =dB(A)

INSTALLATION

Inside Outside
 Explosive area

SERVICE

Continuous Intermittent

MOTOR type / Frame	No Poles	No RevolutionsRPM	Absorbed powerAmp	Installed PowerkW /HP
FrequencyHz	SupplyVolt	Enclosure IP.....	Insulation class	Absorbed PowerkW /HP

COMMENTS

MONOSTAGE CENTRIFUGAL PUMPS

**MAGNETIC DRIVE
MONOSTAGE CENTRIFUGAL PUMPS**

SELF-PRIMING CENTRIFUGAL PUMPS

**MAGNETIC DRIVE
SELF-PRIMING CENTRIFUGAL PUMPS**

MULTISTAGE CENTRIFUGAL PUMPS

LIQUID RING VACUUM PUMPS

LIQUID RING COMPRESSORS

**PACKAGE VACUUM UNITS WITH PARTIAL OR TOTAL
SERVICE LIQUID RECIRCULATION**

NA5.SM.TCH0.GB00 / PRINTED IN ITALY
Smontaggio TC... - MCU... Inglese

POMPETRAVAINI'S continuing research results in product improvement, therefore any specifications may be subject to change without notice.

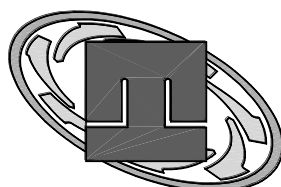

pompetravaini S.p.A.

20022 CASTANO PRIMO (Milano) ITALY
Via per Turbigo, 44 – Zona Industriale
Tel. 0331 889000 – Fax 0331 889090
www.pompetravaini.com

ISO 9001